

MANUFACTURE OF THE PROPRIETARY PARTS SHOWN HERE WITHOUT WRITTEN CONSENT OF ARCONIC FASTENING SYSTEMS IS ABSOLUTELY PROHIBITED.

THIS DRAWING EMBODIES ARCONIC FASTENING SYSTEMS CONFIDENTIAL, PROPRIETARY DESIGN & ALL DESIGN, MANUFACTURING PRODUCTION, USE & SALE RIGHTS REGARDING SAME ARE EXPRESSLY RESERVED.

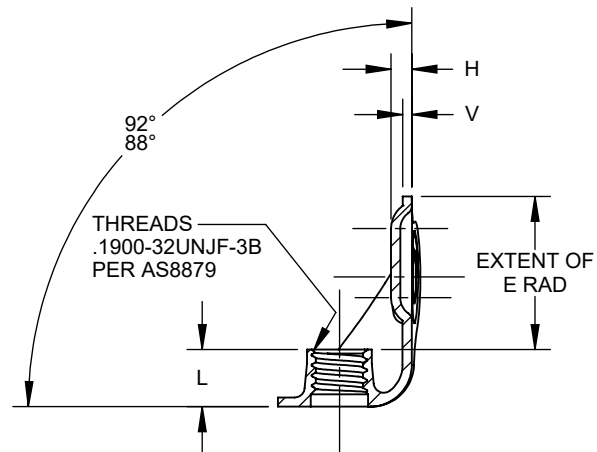
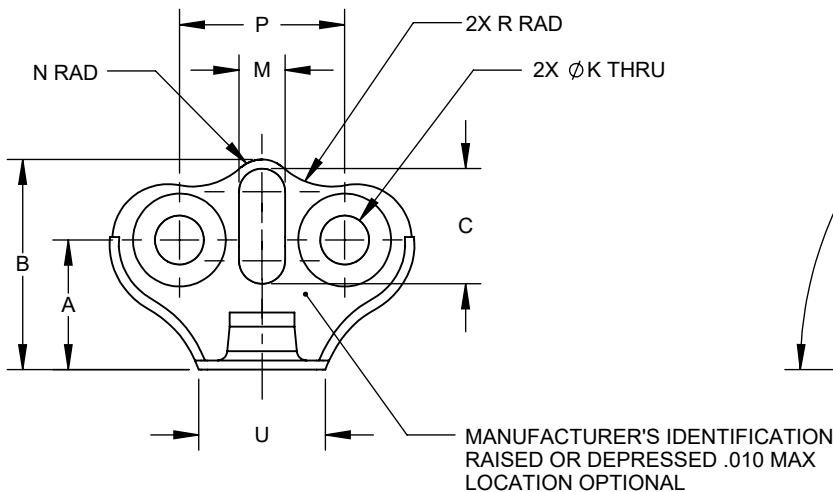
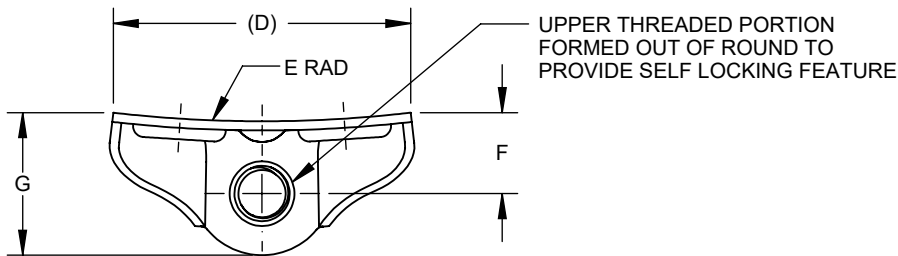

AFS PRODUCTS PART NO.		A	B	C	(D)	E	F	G	H	ØK	L	M	N	P	R	U	V	AXIAL TENSILE STRENGTH lbf MIN
T8296S1032B-	1	.465 .435	.745 .715	.415 .385	1.033	5.500 3.500	.296 .266	.480 .450	.087 .057	.135 .130	.215 .185	.175 .145	.125 .095	.564 .560	.265 .235	.390 .360	.037 .032	2460
	2	.665 .635	.945 .915	.615 .585														
	3	.865 .835	1.145 1.115	.765 .735														

MATERIAL: C1050 CARBON STEEL PER AMS5085 (UNS G10500) OR ASTM A684.

HEAT TREAT: Rc 34-41 PER AMS-H-6875.

FINISH: T8296S1032B-(\*):  
CADMIUM PLATE PER AMS-QQ-P-416, TYPE II, CLASS 2 PLUS SOLID FILM LUBRICANT PER AS5272, TYPE I.  
T8296S1032B-(\*):CPC:  
CADMIUM PLATE PER AMS-QQ-P-416, TYPE II, CLASS 2. NO LUBRICANT

PERFORMANCE: BPS-N-70, CLASS 125TA4, EXCEPT AS FOLLOWS:  
A) AXIAL TENSILE STRENGTH AS TABULATED.

NOTES: 3. UNLESS OTHERWISE SPECIFIED:  
A) DIMENSIONS APPLY AFTER FINISH, BUT BEFORE LUBRICATION.

THIRD ANGLE PROJECTION

EAR EXPORT CONTROLLED TECHNICAL DATA: DISTRIBUTION LIMITED TO U.S. PERSONS OR THOSE NON-U.S. PERSONS COVERED BY AN APPROPRIATE EXPORT LICENSE OR ALLOWED FOR BY THE APPROPRIATE REGULATIONS, ECCN: EAR99.

APPROVED DATE  
15DEC1989

CURRENT DESIGN ACTIVITY:

TITLE:

**CAGE CODE: 52828**

REV. LETTER AND DATE:  
A 07JAN2019



Arconic Fastening Systems  
Fullerton Operations  
800 S State College Boulevard  
Fullerton, California, 92831  
<http://www.arconic.com>

*NUT - ANCHOR,  
RIGHT ANGLE, CURVED BACK  
SELF-LOCKING*

**SALES DRAWING No.**

UNLESS OTHERWISE SPECIFIED, DIMENSIONS ARE  
IN INCHES & TO ASME Y14.5-2009 TOLERANCES:  
DECIMALS = ±.015; ANGLES = ±2°

**T8296S1032B-(\*):(\*)**