

MANUFACTURE OF THE PROPRIETARY PARTS SHOWN HERE WITHOUT WRITTEN CONSENT OF HOWMET FASTENING SYSTEMS IS ABSOLUTELY PROHIBITED.

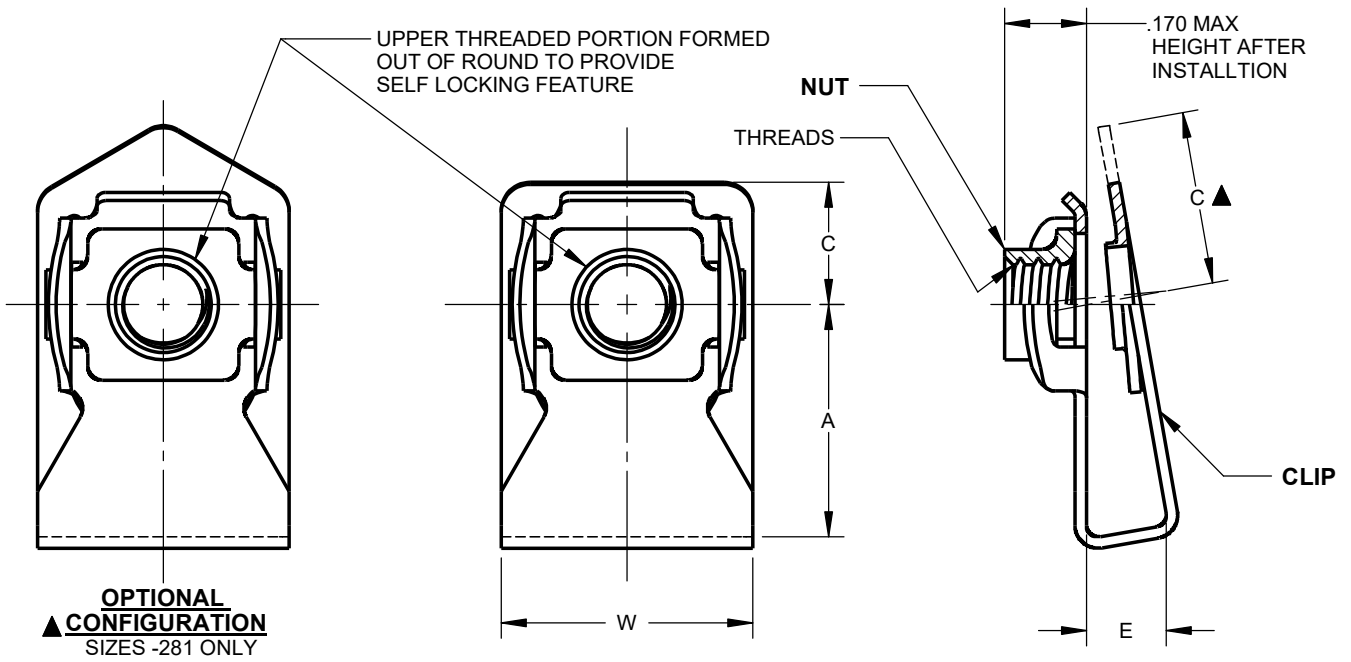

HFS PART NO.	THREADS PER AS8879	A	C	E	W	EDGE DISTANCE	INSTALLATION HOLE SIZE	PANEL THICKNESS RANGE		
		MIN	MAX	MIN	MAX					
SL231-	06 - 1 - 281	.1380-32UNJC-3B	.285	.290	.120	.406	.163 - .173	.020 - .120		
	08 - 1 - 250	.1640-32UNJC-3B		.255	.165	.500			.190 - .229	.020 - .165
	08 - 1 - 281			.290	.115	.281				
	08 - 1 - 375			.385	.120	.375				
	08 - 1 - 500			.510	.160	.500				
	08 - 1 - 625			.650	.220 - .230	.625	.020 - .160			
	3 - 1 - 250			.1900-32UNJF-3B	.255	.165		.500		
	3 - 1 - 281	.290			.115	.281				
	3 - 1 - 375	.385			.120	.375				
	3 - 1 - 500	.510			.160	.500				
	3 - 1 - 625	.650			.220 - .230	.625	.020 - .160			
	3 - 1 - 705	.739			.265	.705		.140 - .265		

MATERIAL: NUT AND CLIP: C1050 CARBON STEEL PER AMS5085 (UNS G10500).

HEAT TREAT: HRC 49 MAX.

FINISH: NUT: CADMIUM PLATE PER AMS-QQ-P-416, TYPE II, CLASS 2, PLUS SOLID FILM LUBE PER AS5272.
CLIP: CADMIUM PLATE PER AMS-QQ-P-416, TYPE II, CLASS 2.

PERFORMANCE: LOCKING TORQUE AND TENSILE PER NASM25027.

EXAMPLE OF PART NUMBER

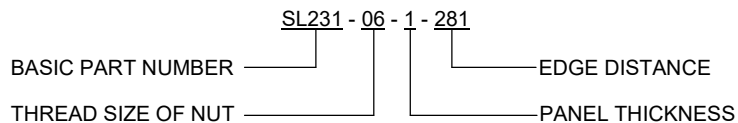

© 2021 HOWMET AEROSPACE INC. ALL RIGHTS RESERVED.

THIRD ANGLE PROJECTION EAR EXPORT CONTROLLED TECHNICAL DATA: DISTRIBUTION LIMITED TO U.S. PERSONS OR THOSE NON-U.S. PERSONS COVERED BY AN APPROPRIATE EXPORT LICENSE OR ALLOWED FOR BY THE APPROPRIATE REGULATIONS, ECCN: EAR99.

FILED AS: s_SL231-(-)-1-(-)

APPROVED DATE 09SEP1993	CURRENT DESIGN ACTIVITY: HOWMET AEROSPACE	TITLE: CLIP - NUT, SELF LOCKING, ASSEMBLY	CAGE CODE: 52828
REV. LETTER AND DATE: L 23SEP2021	Howmet Fastening Systems 800 S State College Boulevard Fullerton, California, 92831 http://www.hfs.howmet.com	UNLESS OTHERWISE SPECIFIED, DIMENSIONS ARE IN INCHES & TO ASME Y14.5-2018 TOLERANCES: DECIMALS = ±.010; ANGLES = ±2°	SALES DRAWING No.
CUSTOMER:			SL231-(-)-1-(-)