

MANUFACTURE OF THE PROPRIETARY PARTS SHOWN HERE WITHOUT WRITTEN CONSENT OF HOWMET FASTENING SYSTEMS IS ABSOLUTELY PROHIBITED.

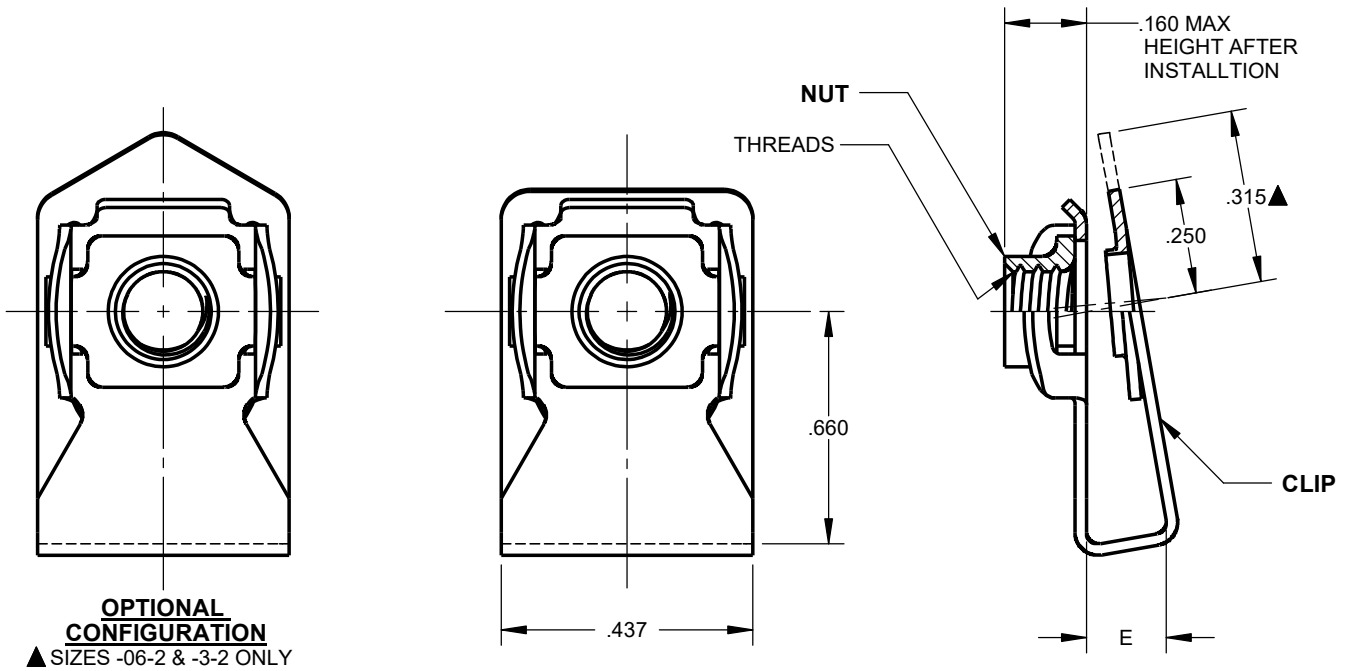

HFS PART NO.	THREADS PER AS8879	E MIN	EDGE DISTANCE	INSTALLATION HOLE SIZE	PANEL THICKNESS RANGE	APPROX WEIGHT lbs/100
06 - 2	.250	.160-.250				
08 - 1	.1640-32UNJC-3B	.160	.190-.229	.020-.160	.51	
08 - 2		.250		.160-.250		
3 - 1	.1900-32UNJF-3B	.160	.218-.261	.020-.160		
3 - 2		.250		.160-.250		

MATERIAL: NUT AND CLIP:
C1050 CARBON STEEL PER AMS5085 (UNS G10500).

HEAT TREAT: HRC 46 MAX.

FINISH: NUT:
CADMIUM PLATE PER AMS-QQ-P-416, TYPE II, CLASS 2, PLUS SOLID FILM LUBE PER AS5272.
CLIP:
CADMIUM PLATE PER AMS-QQ-P-416, TYPE II, CLASS 2.

PERFORMANCE: LOCKING TORQUE AND TENSILE PER NASM25027.

EXAMPLE OF PART NUMBER

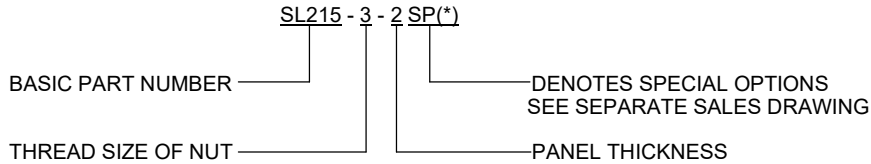

© 2021 HOWMET AEROSPACE INC. ALL RIGHTS RESERVED.

THIRD ANGLE PROJECTION EAR EXPORT CONTROLLED TECHNICAL DATA: DISTRIBUTION LIMITED TO U.S. PERSONS OR THOSE NON-U.S. PERSONS COVERED BY AN APPROPRIATE EXPORT LICENSE OR ALLOWED FOR BY THE APPROPRIATE REGULATIONS, ECCN: EAR99.

APPROVED DATE 09SEP1993	CURRENT DESIGN ACTIVITY: HOWMET AEROSPACE Howmet Fastening Systems 800 S State College Boulevard Fullerton, California, 92831 http://www.hfs.howmet.com	TITLE: CLIP - NUT, SELF LOCKING, ASSEMBLY
REV. LETTER AND DATE: E 16JAN2023		
CUSTOMER:		

CAGE CODE: 52828

SALES DRAWING No.

SL215-(*)-(*)

UNLESS OTHERWISE SPECIFIED, DIMENSIONS ARE IN INCHES & TO ASME Y14.5-2018 TOLERANCES: DECIMALS = ±.010; ANGLES = ±2°

FILED AS: s_SL215-(-)-(-)