

MANUFACTURE OF THE PROPRIETARY PARTS SHOWN HERE WITHOUT WRITTEN CONSENT OF HOWMET FASTENING SYSTEMS IS ABSOLUTELY PROHIBITED.

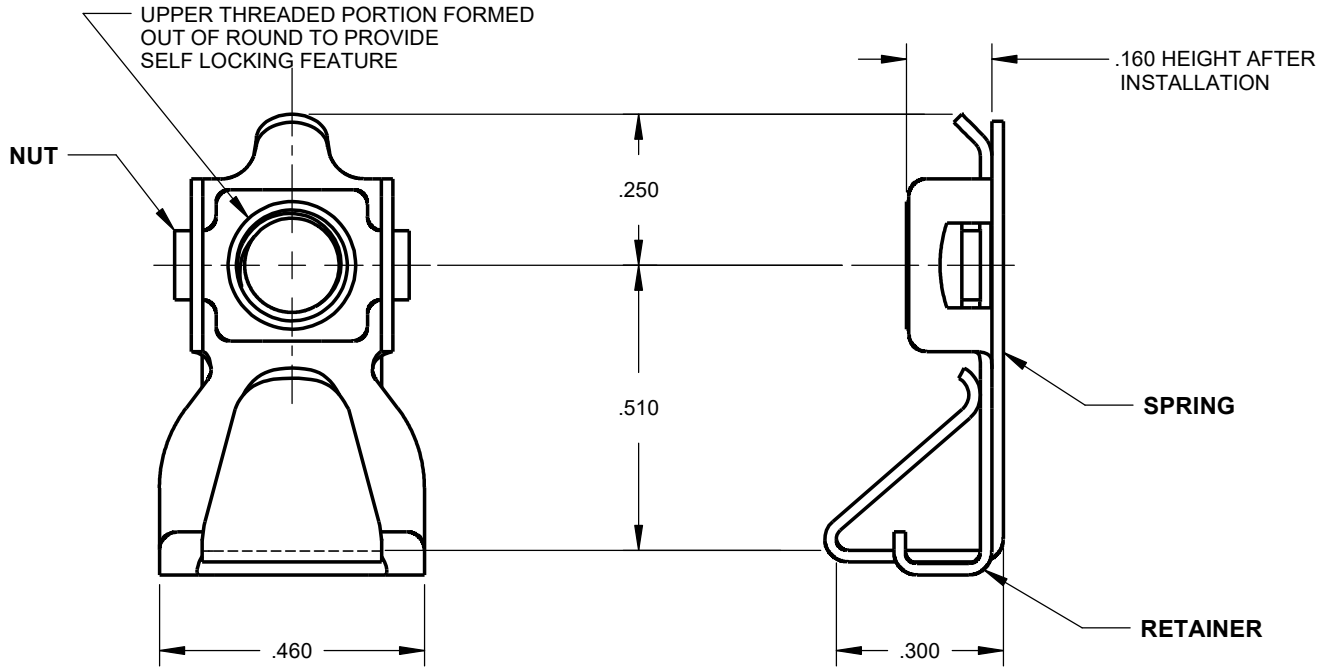

HFS PART NO.	THREADS PER AS8879	PANEL THICKNESS RANGE	EDGE DISTANCE RANGE	INSTALL HOLE SIZE	APPROX WEIGHT lbs/100
SL212-	04-1	.1120-40UNJC-3B	.020-.125	.38-.50	.190-.229
	06-1	.1380-32UNJC-3B			
	08-1	.1640-32UNJC-3B			.54
	3-1	.1900-32UNJF-3B			

MATERIAL: NUT, SPRING AND RETAINER: C1050 CARBON STEEL PER AMS5085 (UNS G10500).

HEAT TREAT: HRC 49 MAX.

FINISH: SPRING AND RETAINER: CADMIUM PLATE PER AMS-QQ-P-416, TYPE II, CLASS 2.

NUT: CADMIUM PLATE PER AMS-QQ-P-416, TYPE II, CLASS 2, PLUS SOLID FILM LUBE PER AS5272 TYPE I.

PERFORMANCE: LOCKING TORQUE AND TENSILE PER NASM25027.

EXAMPLE OF PART NUMBER

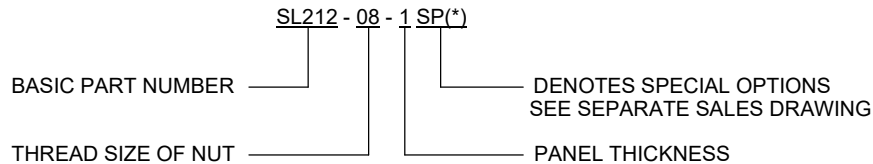

© 2021 HOWMET AEROSPACE INC. ALL RIGHTS RESERVED.

THIRD ANGLE PROJECTION EAR EXPORT CONTROLLED TECHNICAL DATA: DISTRIBUTION LIMITED TO U.S. PERSONS OR THOSE NON-U.S. PERSONS COVERED BY AN APPROPRIATE EXPORT LICENSE OR ALLOWED FOR BY THE APPROPRIATE REGULATIONS, ECCN: EAR99.

APPROVED DATE 09NOV1993
REV. LETTER AND DATE: F 07JUN2021
CUSTOMER:

CURRENT DESIGN ACTIVITY:



Howmet Fastening Systems
800 S State College Boulevard
Fullerton, California, 92831
<http://www.hfs.howmet.com>

TITLE: NUT - CLIP, SELF LOCKING, ASSEMBLY
<i>UNLESS OTHERWISE SPECIFIED, DIMENSIONS ARE IN INCHES & TO ASME Y14.5-2018 TOLERANCES: DECIMALS = ±.010; ANGLES = ±2°</i>

CAGE CODE: 52828
SALES DRAWING No.
SL212-(*)-(*)
SHEET 1 OF 1

FILED AS: s_SL212-(-)-1