

MANUFACTURE OF THE PROPRIETARY PARTS SHOWN HERE WITHOUT WRITTEN CONSENT OF ARCONIC FASTENING SYSTEMS IS ABSOLUTELY PROHIBITED.

THIS DRAWING EMBODIES ARCONIC FASTENING SYSTEMS CONFIDENTIAL, PROPRIETARY DESIGN & ALL DESIGN, MANUFACTURING PRODUCTION, USE & SALE RIGHTS REGARDING SAME ARE EXPRESSLY RESERVED.

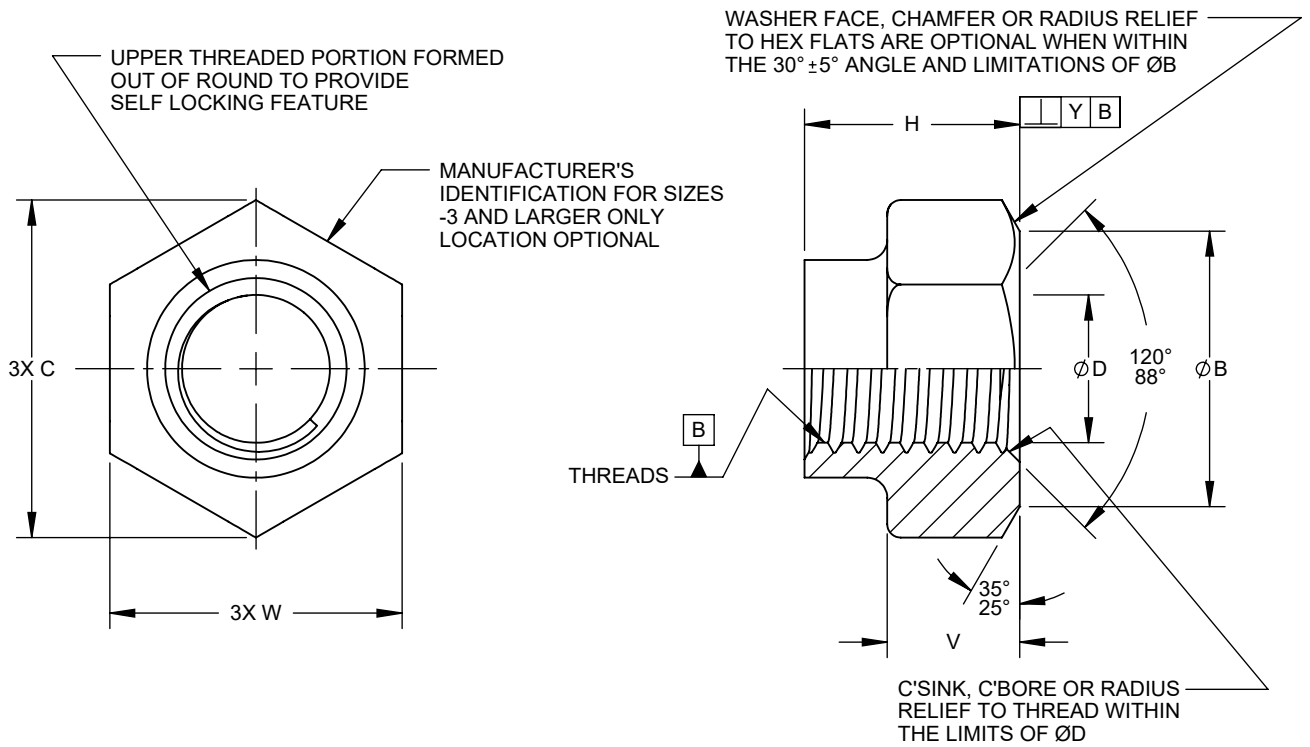

AFS PRODUCTS PART NO.	THREADS PER AS8879	ØB MIN	C MIN	ØD	H	V MIN	W	Y	AXIAL TENSILE STRENGTH lbf MIN	APPROX WEIGHT lbs/100	
H55-	04	.1120-40UNJC-3B	.223	.268	.151 .121	.167 .133	.044	.251 .243	.004	750	.16
	06	.1380-32UNJC-3B	.285	.339	.176 .146	.188 .160	.072	.313 .305		1,130	.30
	08	.1640-32UNJC-3B	.316	.374	.203 .173	.250 .219	.091	.345 .336		1,720	.50
	1024	.1900-32UNJC-3B	.347	.410	.230	.250	.085	.376		2,460	.58
	3	.1900-32UNJF-3B			.200	.208		.367			
	420	.2500-28UNJC-3B	.410	.482	.293 .263	.328 .240	.116	.439 .430	.005	4,580	.99
	4	.2500-28UNJF-3B									
	5	.3125-24UNJF-3B	.472	.552	.356 .326	.360 .271	.123	.502 .492	.006	7,390	1.40
	6	.3750-24UNJF-3B	.533	.622	.410 .388	.469 .318		.153		.564 .553	11,450
	7	.4375-20UNJF-3B	.669	.766	.478 .448	.469 .435	.178	.690 .679	.007	16,450	3.40
8	.5000-20UNJF-3B	.721	.837	.551 .521	.610 .575	.221		.752 .741		21,110	4.70

MATERIAL: 8740 ALLOY STEEL PER AMS6322 (UNS G87400), HEAT TREATED.

FINISH: H55-(*):
CADMIUM PLATE PER AMS-QQ-P-416, TYPE II, CLASS 2, PLUS SOLID FILM LUBRICANT COAT PER AS5272, TYPE I.

H55-(*):CW:
CADMIUM PLATE PER AMS-QQ-P-416, TYPE II, CLASS 2, PLUS WAX.

PERFORMANCE: NASM25027.

- NOTES: 1. UNLESS OTHERWISE SPECIFIED:
 A) DIMENSIONS APPLY AFTER FINISH BUT PRIOR TO THE APPLICATION OF SOLID FILM LUBRICANT.
 B) SURFACE TEXTURE 125 MICROINCHES PER ASME B46.1.
 C) REMOVE ALL BURRS AND SHARP EDGES.

THIRD ANGLE PROJECTION

EAR EXPORT CONTROLLED TECHNICAL DATA: DISTRIBUTION LIMITED TO U.S. PERSONS OR THOSE NON-U.S. PERSONS COVERED BY AN APPROPRIATE EXPORT LICENSE OR ALLOWED FOR BY THE APPROPRIATE REGULATIONS, ECCN: EAR99.

APPROVED DATE

20JUN1991

CURRENT DESIGN ACTIVITY:



ARCONIC

Arconic Fastening Systems
Fullerton Operations
800 S State College Boulevard
Fullerton, California, 92831

<http://www.arconic.com>

TITLE:

NUT - HEX
SELF-LOCKING

CAGE CODE: 15653

SALES DRAWING No.

H55-(*)

UNLESS OTHERWISE SPECIFIED, DIMENSIONS ARE IN INCHES & TO ASME Y14.5-2009 TOLERANCES: DECIMALS = ±.015; ANGLES = ±2°

REV. LETTER AND DATE:
A 07DEC2018

CUSTOMER: