



HOWMET
AEROSPACE

MANUFACTURE OF THE PROPRIETARY PARTS SHOWN HERE WITHOUT WRITTEN CONSENT OF HOWMET FASTENING SYSTEMS IS ABSOLUTELY PROHIBITED.

THIS DRAWING EMBODIES A CONFIDENTIAL PROPRIETARY DESIGN & ALL DESIGN, MANUFACTURING PRODUCTION, USE & SALE RIGHTS REGARDING SAME ARE EXPRESSLY RESERVED.

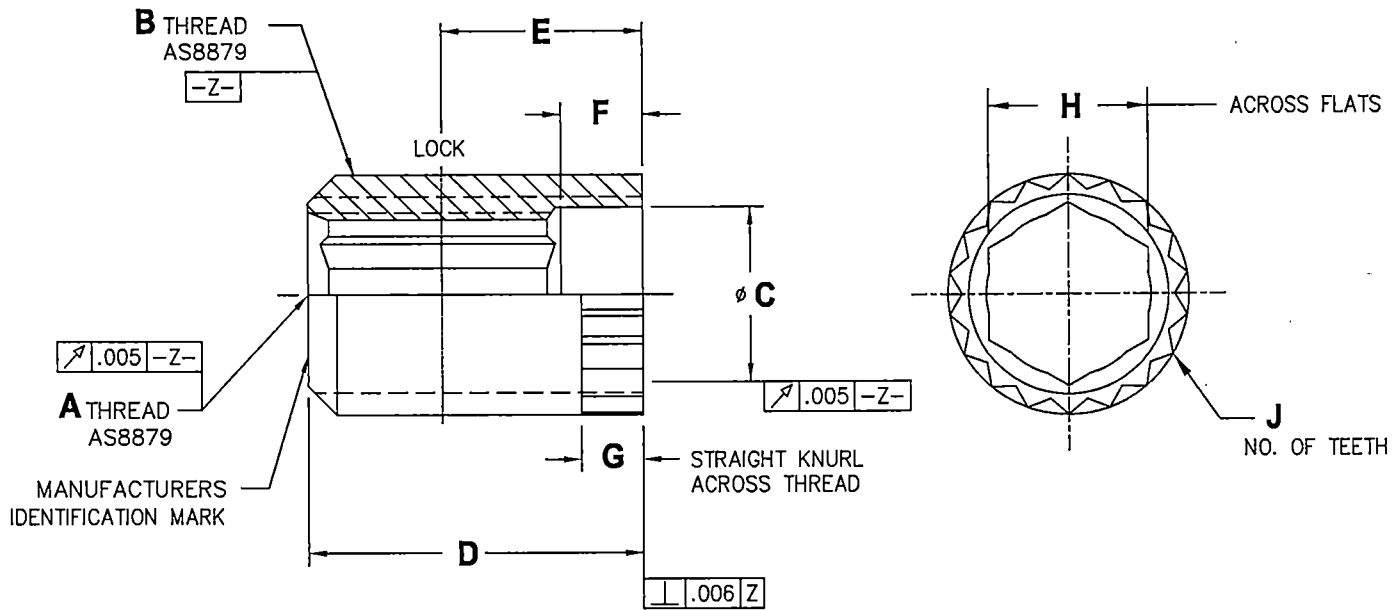

FIGURE 1

TABLE 1: PARTS DIMENSIONS AND WEIGHTS

ROSAN PART NUMBER	S.B.A.C. PART NUMBER REF	SAE PART NUMBER REF	A THREAD SIZE	B THREAD MODIFIED MINOR DIA	
				THREAD SIZE	MINOR DIA MAX
SRQ192L0074	AS52760	AS3504-01	.1900-32UNJF-3B	.2500-28UNJF-3A	.2170
SRQ258L0074	AS52761	AS3504-02	.2500-28UNJF-3B	.3125-24UNJF-3A	.2785
SRQ314L0074	AS52762	AS3504-03	.3125-24UNJF-3B	.3750-24UNJF-3A	.3405
SRQ374L0074	AS52763	AS3504-04	.3750-24UNJF-3B	.4375-20UNJF-3A	.4010
SRQ430L0074	-	AS3504-05	.4375-20UNJF-3B	.5000-20UNJF-3A	.4630
SRQ500L0074	-	AS3504-06	.5000-20UNJF-3B	.5625-24UNJEF-3A	.5290

ROSAN PART NUMBER	ϕC	D	E	F	G	H	J	WEIGHT APPROX
	$\pm .003$	$\pm .010$	REF	$\pm .005$	$\pm .005$	REF		lbs/1000 PCS
SRQ192L0074	.196	.290	.19	.090	.075	.157	20	1.264
SRQ258L0074	.256	.380	.24	.090	.075	.210	24	2.285
SRQ314L0074	.318	.470	.30	.090	.075	.266	29	3.570
SRQ374L0074	.382	.560	.35	.120	.105	.322	34	5.024
SRQ430L0074	.444	.660	.40	.120	.105	.377	39	7.751
SRQ500L0074	.507	.750	.45	.120	.105	.439	44	9.816

APPROVED DATE 89-06-28	CURRENT DESIGN ACTIVITY: Howmet Fastening Systems (HFS)	TITLE: INSERT - THIN WALL, SHORT, SELF-LOCKING, 1025°F SILVER PLATED	CURRENT DESIGN ACTIVITY: CAGE CODE: 83324
REV. LETTER AND DATE N 06/01/20	TORRANCE OPERATIONS		SALES DRAWING NO.
DAF NUMBER 119439	Rosan Products 3018 W. Lomita Blvd. Torrance, California 90505-5103	UNLESS OTHERWISE SPECIFIED DIMENSIONS ARE IN INCHES & ASME Y14.5M TOLERANCES:	SRQ(L)0074 SERIES
		ANGLES = $\pm 3^\circ$ DECIMALS .XX = $\pm .02$.XXX = $\pm .010$	SHEET 1 OF 6



MANUFACTURE OF THE PROPRIETARY PARTS SHOWN HERE WITHOUT WRITTEN CONSENT OF HOWMET FASTENING SYSTEMS IS ABSOLUTELY PROHIBITED.

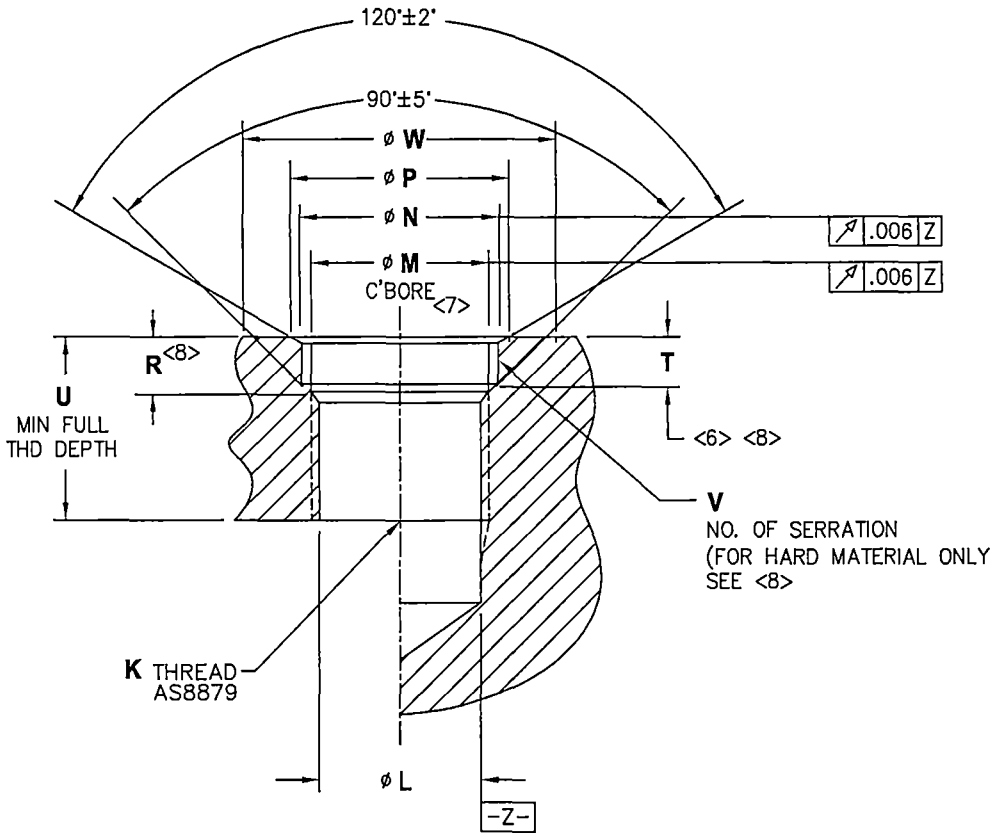

FIGURE 2

TABLE 2: HOLE PREPARATION DIMENSIONS

PART NUMBER	K THREAD SIZE	ϕL TAP HOLE	ϕM +.005 -.000	ϕN SERRATION MAJOR DIA +.003 -.002	ϕP $\pm .006$	R C'BORE DEPTH $\langle 8 \rangle$ $\pm .005$	T SERRATION DEPTH $\langle 8 \rangle$ $\pm .010$
SRQ192L0074	.2500-28UNJF-3B	.220-.225	.249	.266	.297	.096	.077
SRQ258L0074	.3125-24UNJF-3B	.280-.285	.311	.336	.364	.096	.077
SRQ314L0074	.3750-24UNJF-3B	.342-.347	.374	.402	.431	.096	.077
SRQ374L0074	.4375-20UNJF-3B	.403-.408	.436	.459	.486	.128	.108
SRQ430L0074	.5000-20UNJF-3B	.467-.472	.499	.525	.553	.128	.108
SRQ500L0074	.5625-24UNJEF-3B	.530-.535	.561	.582	.612	.128	.108

PART NUMBER	U MIN	V	ϕW BOSS DIA $\langle 9 \rangle$ MIN	STEP DRILL	WOBBLE BROACH	SERRATION GAGE
SRQ192L0074	.325	20	.410	SR19D	SRPBT19WBA	SR19HSG
SRQ258L0074	.415	24	.470	SR25D	SRPBT25WBA	SR25HSG
SRQ314L0074	.505	29	.540	SR31D	SRPBT31WBA	SR31HSG
SRQ374L0074	.595	34	.600	SR37D	SRPBT37WBA	SR37HSG
SRQ430L0074	.695	39	.660	SR43D	SRPBT43WBA	SR43HSG
SRQ500L0074	.785	44	.720	SR50D	SRPBT50WBA	SR50HSG

THIS DRAWING EMBODIES A CONFIDENTIAL, PROPRIETARY DESIGN & ALL DESIGN, MANUFACTURING PRODUCTION, USE & SALE RIGHTS REGARDING SAME ARE EXPRESSLY RESERVED.

APPROVED DATE 89-06-28	CURRENT DESIGN ACTIVITY: Howmet Fastening Systems (HFS)	TITLE: INSERT - THIN WALL, SHORT, SELF-LOCKING, 1025°F SILVER PLATED	CURRENT DESIGN ACTIVITY: CAGE CODE: 83324
REV. LETTER AND DATE N 06/01/20	TORRANCE OPERATIONS		SALES DRAWING NO.
DAF NUMBER 119439	Rosan Products 3018 W. Lomita Blvd. Torrance, California 90505-5103	UNLESS OTHERWISE SPECIFIED DIMENSIONS ARE IN INCHES & ASME Y14.5M TOLERANCES:	SRQ()L0074 SERIES SHEET 2 OF 6

ANGLES = $\pm 3'$
DECIMALS .XX = $\pm .02$
.XXX = $\pm .010$



HOWMET
AEROSPACE

NOTES:

1. MATERIAL: INCONEL 718 PER AMS 5662.
2. HEAT TREAT: 37-43 HRC.
3. FINISH:
 - a. INTERNAL SURFACES: SILVER PLATE PER AMS 2411, .0002 MIN THICKNESS.
 - b. EXTERNAL SURFACES: PASSIVATE PER AMS 2700.
4. SURFACE TEXTURE: SYMBOLS PER ASME Y14.36. REQUIREMENTS PER ASME B46.1. SURFACES TO BE 125 MICROINCH R_a , EXCEPT THREADS TO BE 63 MICROINCH R_a AND KNURL TO BE 250 MICROINCH R_a .
5. BREAK SHARP EDGES .015 MAX.
- <6> CHIP REMOVAL REQUIRED AFTER BROACHING SERRATIONS.
- <7> THREAD MARKS PERMISSIBLE IN COUNTERBORE AREA.
- <8> FOR HARD MATERIALS ABOVE 187 BHN (3000 kgf AND 10mm BALL) E.G. STEEL, NICKEL, TITANIUM, ETC. A SERRATED C'BORE IS REQUIRED IN THE INSTALLATION HOLE. FOR SOFT LIGHT ALLOY MATERIALS NOT EXCEEDING 187 BHN (3000 kgf LOAD AND 10mm BALL) E.G. ALUMINIUM, MAGNESIUM, ETC. USE A PLAIN C'BORE IN THE INSTALLATION HOLE.
- <9> THE RECOMMENDED BOSS DIAMETER WILL ALSO DEPEND ON COMPONENT APPLICATION, METHOD OF MANUFACTURE, AND ALLOWANCES FOR SALVAGE.
10. PERFORMANCE REQUIREMENTS PER S.B.A.C SPECIFICATION NO TS138 AND SAE PROCUREMENT SPECIFICATION NO AS3506.

INSTALLATION AND REMOVAL PROCEDURE:

1. GENERAL DESIGN INFORMATION:

- 1.1 THESE SELF LOCKING INSERTS SHALL HAVE KNURLED AREAS INDENTED INTO PARENT MATERIAL TO PREVENT ROTATIONAL MOVEMENT DURING SERVICE AND WHILE ASSEMBLING OR REMOVING THE MATING BOLT.
- 1.2 THE SRQ()L0074 SHORT INSERT SERIES ARE PRIMARILY DESIGNED FOR USE IN HARD MATERIALS (E.G. STEELS, NICKEL, TITANIUM, ETC.) AT 1025°F MAXIMUM OPERATING TEMPERATURE. FOR APPLICATION IN SOFT LIGHT ALLOY MATERIALS (E.G. ALUMINIUM, MAGNESIUM, ETC.), USE SRQB()L0024 LONG INSERT SERIES.

2. INSTALLATION OF INSERT

- 2.1 APPLY A CORROSION PROTECTIVE COATING IN THE PREPARED HOLE IF APPLICABLE.
- 2.2 INSERTS INSTALLED IN STEEL, HEAT RESISTING ALLOY OR TITANIUM ALLOY COMPONENTS MAY BE LIGHTLY SMEARED EXTERNALLY WITH CLEAN ENGINE OIL (I.E. ANY OF THE RECOGNIZED OILS USED FOR THE ENGINE LUBRICATION SYSTEM).
- 2.3 ENGAGE THE HEX OF APPLICABLE DRIVE WRENCH PER TABLE 3 INTO INSERT AND WRENCH INSERT INTO THE HOLE TO .010 TO .020 DEPTH AS SHOWN IN FIGURE 3.

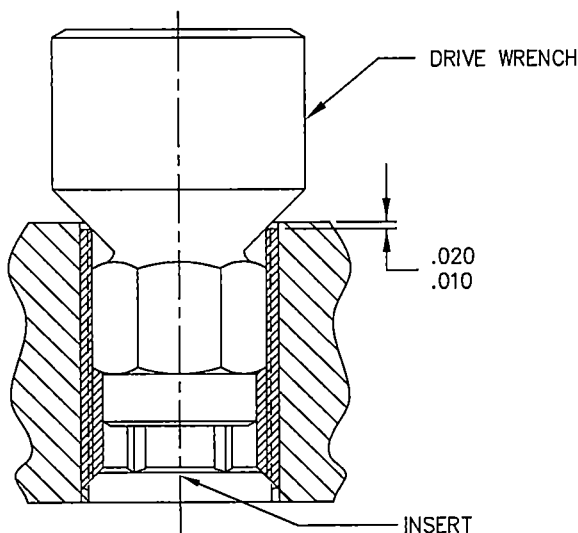

FIGURE 3

INSERT PART NUMBER	DRIVE WRENCH NUMBER
SRQ192L0074	SR19WA
SRQ258L0074	SR25WA
SRQ314L0074	SR31WA
SRQ374L0074	SR37WA
SRQ430L0074	SR43WA
SRQ500L0074	SR50WA

TABLE 3: DRIVE WRENCH

APPROVED DATE 89-06-28	CURRENT DESIGN ACTIVITY: Howmet Fastening Systems (HFS)	TITLE: INSERT - THIN WALL, SHORT, SELF-LOCKING, 1025°F SILVER PLATED	CURRENT DESIGN ACTIVITY: CAGE CODE: 83324
REV. LETTER AND DATE N 06/01/20	TORRANCE OPERATIONS		SALES DRAWING NO.
DAF NUMBER 119439	Rosan Products 3018 W. Lomita Blvd. Torrance, California 90505-5103	UNLESS OTHERWISE SPECIFIED DIMENSIONS ARE IN INCHES & ASME Y14.5M TOLERANCES:	SRQ()L0074 SERIES
		ANGLES = ±3° DECIMALS .XX = ±.02 .XXX = ±.010	SHEET 3 OF 6

MANUFACTURE OF THE PROPRIETARY PARTS SHOWN HERE WITHOUT WRITTEN CONSENT OF HOWMET FASTENING SYSTEMS IS ABSOLUTELY PROHIBITED.

THIS DRAWING EMBODIES A CONFIDENTIAL PROPRIETARY DESIGN & ALL DESIGN, MANUFACTURING PRODUCTION, USE & SALE RIGHTS REGARDING SAME ARE EXPRESSLY RESERVED.



HOWMET
AEROSPACE

- 2.4 CAUTION: WHEN A SERRATED COUNTERBORE IS USED, ENSURE THAT THE KNURLS AROUND THE INSERT LINE UP WITH THE COUNTERBORE SERRATIONS..
- 2.5 BEFORE SWAGING, ENSURE STRUCTURE IS SUFFICIENTLY SUPPORTED. POSITION APPLICABLE SWAGE TOOL PER TABLE 4 INTO INSERT AND APPLY A DOWNWARD FORCE SUFFICIENT TO BOTTOM THE NYLON STOP AGAINST THE PARENT MATERIAL AS SHOWN IN FIGURE 4. THE INSERT IS NOW SWAGED AND LOCKED.
- 2.6 DETAIL INSTALLATION REQUIREMENTS OF THESE INSERTS ARE DESCRIBED IN AS3507.

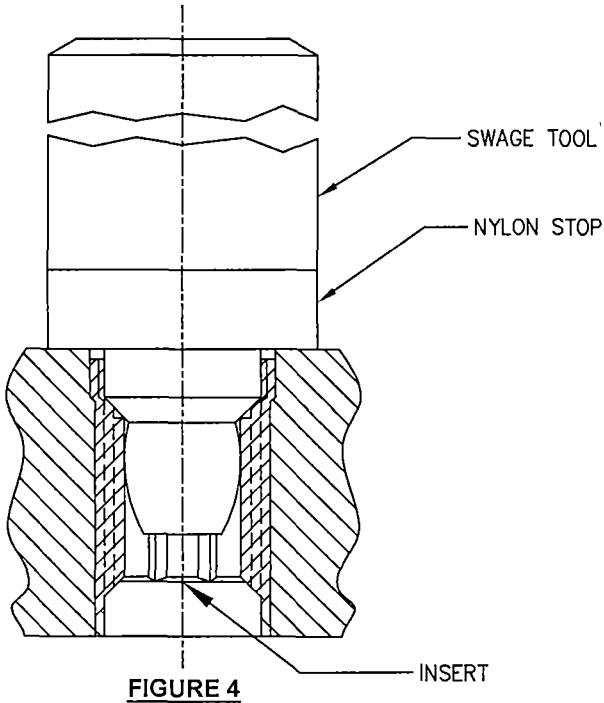

FIGURE 4

INSERT PART NUMBER	SWAGE TOOL NUMBER
SRQ192L0074	SRQ19SA
SRQ258L0074	SRQ25SA
SRQ314L0074	SRQ31SA
SRQ374L0074	SRQ37SA
SRQ430L0074	SRQ43SA
SRQ500L0074	SRQ50SA

TABLE 4: SWAGE TOOL

3. INSPECTION AND GAUGING

3.1 AFTER SWAGE INSPECTION

AFTER THE INSERT HAS BEEN SWAGED AND THE NYLON STOP WASHER HAS CONTACTED THE PARENT MATERIAL SURFACE, THE SWAGED INSERT SHALL CONFORM TO THE DIMENSIONAL REQUIREMENTS OF FIGURE 5 AND TABLE 5.

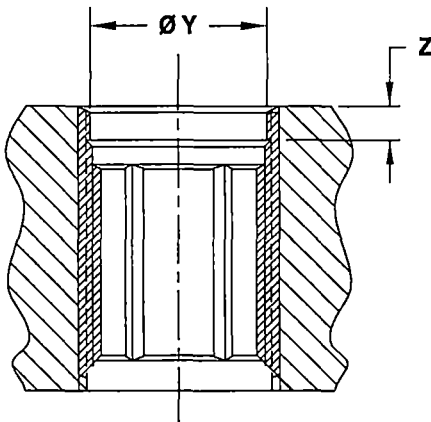

FIGURE 5

INSERT PART NUMBER	ØY	Z
	MIN	±.005
SRQ192L0074	.209	.072
SRQ258L0074	.278	.070
SRQ314L0074	.343	.084
SRQ374L0074	.406	.091
SRQ430L0074	.468	.095
SRQ500L0074	.533	.095

TABLE 5: INSPECTION DIMENSIONS

MANUFACTURE OF THE PROPRIETARY PARTS SHOWN HERE WITHOUT WRITTEN CONSENT OF HOWMET FASTENING SYSTEMS IS ABSOLUTELY PROHIBITED.

THIS DRAWING EMBODIES A CONFIDENTIAL, PROPRIETARY DESIGN & ALL DESIGN, MANUFACTURING PRODUCTION, USE & SALE RIGHTS REGARDING SAME, ARE EXPRESSLY RESERVED.

APPROVED DATE 89-06-28	CURRENT DESIGN ACTIVITY: Howmet Fastening Systems (HFS) TORRANCE OPERATIONS	TITLE: INSERT - THIN WALL, SHORT, SELF-LOCKING, 1025°F SILVER PLATED	CURRENT DESIGN ACTIVITY: CAGE CODE: 83324
REV. LETTER AND DATE N 06/01/20	Rosan Products 3018 W. Lomita Blvd. Torrance, California 90505-5103	UNLESS OTHERWISE SPECIFIED DIMENSIONS ARE IN INCHES ± ASME Y14.5M TOLERANCES:	SALES DRAWING NO.
DAF NUMBER 119439		ANGLES = ±3' DECIMALS .XX = ±.02 .XXX = ±.010	SRQ()L0074 SERIES
			SHEET 4 OF 6



MANUFACTURE OF THE PROPRIETARY PARTS SHOWN HERE WITHOUT WRITTEN CONSENT OF HOWMET FASTENING SYSTEMS IS ABSOLUTELY PROHIBITED.

THIS DRAWING EMBODIES A CONFIDENTIAL, PROPRIETARY DESIGN & ALL DESIGN, MANUFACTURING PRODUCTION, USE & SALE RIGHTS REGARDING SAME ARE EXPRESSLY RESERVED.

3.2 AFTER SWAGE GAGING (RECOMMENDED METHOD):
 AFTER THE INSERT HAS BEEN SWAGED, USE THE APPROPRIATE GAGE PER FIGURE 6 AND TABLE 6. INSERT THE "GO" END ("G") OF THE GAGE INTO THE COUNTERBORE OF THE INSERT. THE SHOULDER OF THE GAGE MUST REST FLUSH WITH THE FACE OF THE PARENT MATERIAL, THIS INDICATES THAT THE INSERT HAS BEEN SUCCESSFUL SWAGED, OTHERWISE, THE INSTALLATION IS NOT ACCEPTABLE (SEE FIGURE 7). NOW INSERT THE "NO GO" END ("N") OF THE GAGE INTO THE COUNTERBORE. THE SHOULDER MUST NOW BE CLEAR OF THE PARENT MATERIAL SURFACE TO INDICATE THE INSERT HAS NOT BEEN DRIVEN TOO DEEP, OTHERWISE, THE INSTALLATION IS NOT ACCEPTABLE (SEE FIGURE 8).
 WHEN BOTH "GO" AND "NO GO" CONDITIONS ARE ACCEPTABLE, THE INSTALLATION IS CORRECT AND THE INSERT IS READY FOR USE.

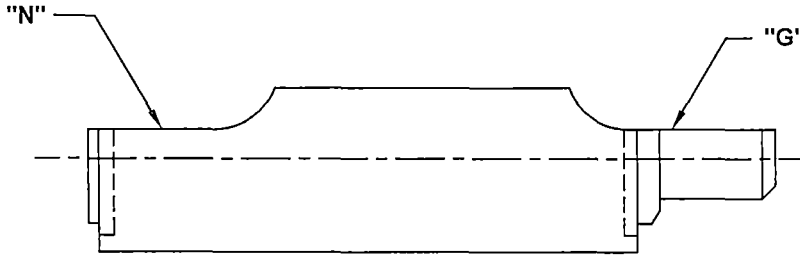

FIGURE 6

INSERT PART NUMBER	AFTER SWAGE GAGE NUMBER
SRQ192L0074	SRQ19GSDA
SRQ258L0074	SRQ25GSDA
SRQ314L0074	SRQ31GSDA
SRQ374L0074	SRQ37GSDA
SRQ430L0074	SRQ43GSDA
SRQ500L0074	SRQ50GSDA

TABLE 6: SWAGE GAGE

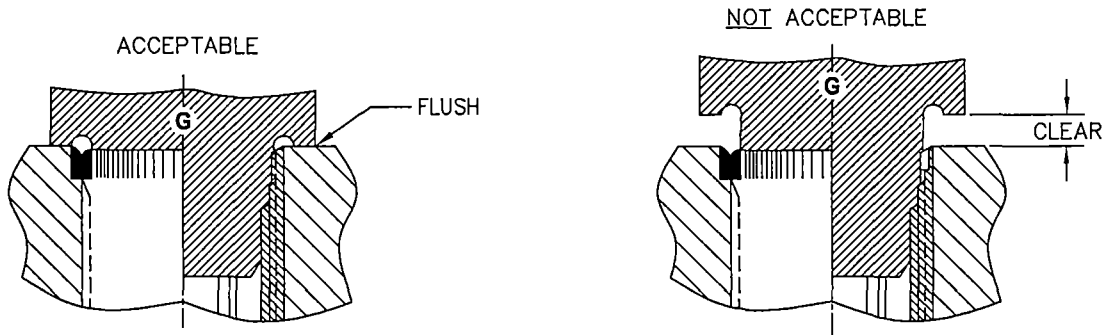

FIGURE 7

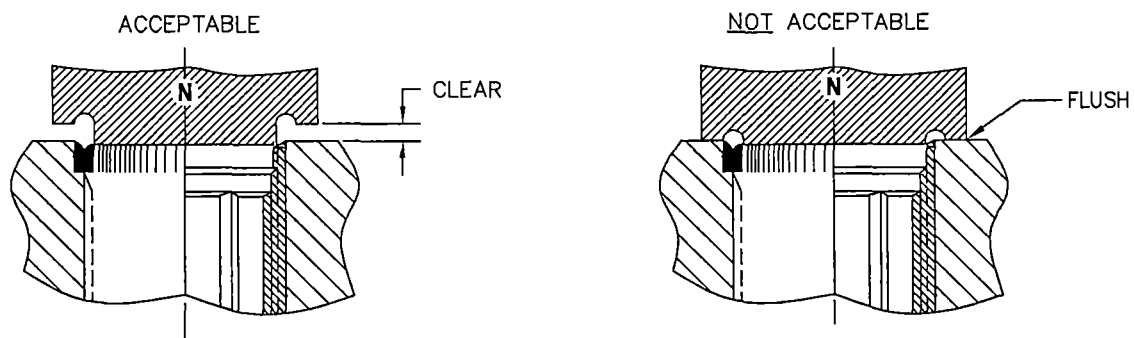

FIGURE 8

APPROVED DATE 89-06-28	CURRENT DESIGN ACTIVITY: Howmet Fastening Systems (HFS)	TITLE: INSERT - THIN WALL, SHORT, SELF-LOCKING, 1025°F SILVER PLATED	CURRENT DESIGN ACTIVITY: CAGE CODE: 83324
REV. LETTER AND DATE N 06/01/20 2	TORRANCE OPERATIONS Rosan Products 3018 W. Lomita Blvd. Torrance, California 90505-5103	UNLESS OTHERWISE SPECIFIED DIMENSIONS ARE IN INCHES & ASME Y14.5M TOLERANCES:	SALES DRAWING NO.
DAF NUMBER 119439		ANGLES = ±3° DECIMALS .XX = ±.02 .XXX = ±.010	SRQ()L0074 SERIES
			SHEET 5 OF 6



**HOWMET
AEROSPACE**

MANUFACTURE OF THE PROPRIETARY PARTS SHOWN HERE WITHOUT WRITTEN CONSENT OF HOWMET FASTENING SYSTEMS IS ABSOLUTELY PROHIBITED.

THIS DRAWING EMBODIES A CONFIDENTIAL PROPRIETARY DESIGN & ALL DESIGN, MANUFACTURING PRODUCTION, USE & SALE RIGHTS REGARDING SAME ARE EXPRESSLY RESERVED.

4. REMOVAL OF INSERT:
- 4.1 POSITION THE PILOT OF APPLICABLE TOOL PER TABLE 7 INTO INSERT AND DRILL DOWN TO DEPTH SHOWN IN FIGURE 9, TABLE 7.

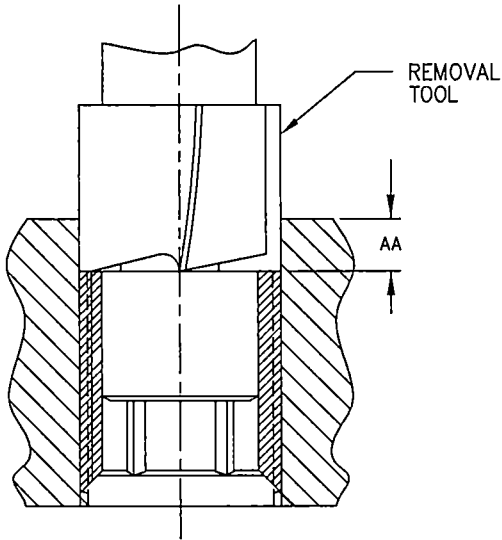

FIGURE 9

INSERT PART NUMBER	REMOVAL TOOL	AA MAX
SRQ192L0074	SR19R	.101
SRQ258L0074	SR25R	.101
SRQ314L0074	SR31R	.101
SRQ374L0074	SR37R	.133
SRQ430L0074	SR43R	.133
SRQ500L0074	SR50R	.133

TABLE 7: REMOVAL TOOL AND DRILL DEPTH

- 4.2 USE APPLICABLE DRIVE WRENCH PER TABLE 3 TO BACK OUT THE REMAINING PORTION OF INSERT.
- 4.3 CLEAN OUT AND REINSPECT HOLE, THEN INSTALL NEW INSERT.

APPROVED DATE 89-06-28	CURRENT DESIGN ACTIVITY: Howmet Fastening Systems (HFS) TORRANCE OPERATIONS	TITLE: INSERT - THIN WALL, SHORT, SELF-LOCKING, 1025°F SILVER PLATED	CURRENT DESIGN ACTIVITY: CAGE CODE: 83324
REV. LETTER AND DATE N 06/01/20 <i>dw</i>			SALES DRAWING NO.
DAF NUMBER 119439	Rosan Products 3018 W. Lomita Blvd. Torrance, California 90505-5103	UNLESS OTHERWISE SPECIFIED DIMENSIONS ARE IN INCHES & ASME Y14.5M TOLERANCES:	SRQ()L0074 SERIES SHEET 6 OF 6