

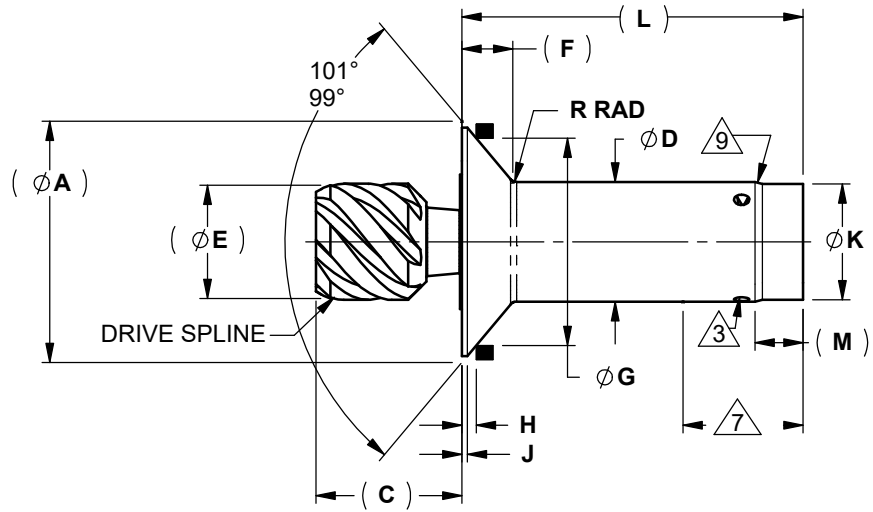

Howmet Fastening Systems  
 Tucson Operations  
 3724 East Columbia Street  
 Tucson, Arizona 85714 USA  
 Phone (520) 519-7400  
 Fax (520) 519-7454

**Ergo-Tech®**  
**BLIND BOLT**  
**ENGINEERING**  
**STANDARD**

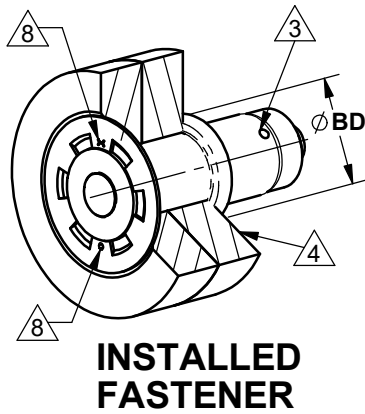

**TABLE I**

PART/DIA. DASH NO.	(Ø A) THEO INTER REF	J MAX	(C) DRIVER LENGTH REF	Ø D SHANK	(Ø E) SPLINE REF	(F) HEAD HEIGHT REF	R RADIUS MAX	Ø G GAUGE	H GAUGE HEIGHT	SINGLE	TENSILE	Ø K LEAD- IN	(M) REF	Ø BD MIN		RECOMMENDED INSTALLATION HOLE SIZES
										LBS (MIN) 1	LBS (MIN) 1			5	EXTENDED GRIP 6	
ER213-05	.3304	.010	.250	.1635 .1625	.180	.070	.015	.2832 .2830	.0202 .0175	2005	1400	.1565 .1539	.060	.205	.167 .164	
ER213-06	.3813	.015	.250	.1895 .1885	.180	.081	.015	.3272 .3270	.0230 .0200	2690	1600	.1830 .1804	.065	.238	.193 .190	
ER213-08	.5066	.015	.300	.2495 .2485	.235	.108	.020	.4320 .4318	.0322 .0288	4650	3000	.2430 .2404	.085	.313	.253 .250	
ER213-10	.6335	.015	.350	.3120 .3110	.275	.135	.025	.5451 .5449	.0378 .0342	7300	5000	.3055 .3029	.230	.391	.316 .313	
ER213-12	.7604	.020	.400	.3745 .3735	.320	.161	.030	.6582 .6580	.0439 .0401	10500	7000	.3680 .3654	.305	.469	.378 .375	

DIMENSIONS IN INCHES

<b>AC</b>	ECN 15069 - TABLE REFORMATTING		Current Design Activity CAGE Code 0HDW7		PROCUREMENT SPEC T0108	DRAWN BY J. SCHLOBOHM
	ISSUED	05/15/2007	BLIND BOLT FASTENER, HIGH STRENGTH, FRICTION THREAD LOCK, THREADED, 100° FLUSH TENSION HEAD, CLOSE TOLERANCE SHANK, TITANIUM/A-286 (95 KSI SHEAR)			CHECKED BY SIGNATURE ON FILE
REVISED	05/15/2022	<b>ER213</b>				
PAGE	1 OF 4	<b>SK12822</b>				

This drawing/documentation is controlled by either the Department of State, International Traffic In Arms Regulations or the Department of Commerce, Export Administration Regulations and may require an export license/license exception prior to being transferred to a foreign national, inside or outside of the United States. EAR/ECCN EAR99. These commodities, technology or software were exported from the United States in accordance with the Export Administration Regulations. Diversion contrary to U.S. law prohibited.

THIS DRAWING, THE STRUCTURAL DESIGN DISCLOSED THEREIN AND THE TECHNICAL DATA AND ENGINEERING SERVICE REPRESENTED THEREBY ARE THE EXCLUSIVE PROPERTY OF HUCK INTERNATIONAL, INC.



Howmet Fastening Systems  
 Tucson Operations  
 3724 East Columbia Street  
 Tucson, Arizona 85714 USA  
 Phone (520) 519-7400  
 Fax (520) 519-7454

**Ergo-Tech®**  
**BLIND BOLT**  
**ENGINEERING**  
**STANDARD**

**TABLE II**

GRIP NUMBER TABULATION								$\triangle_{10}$	
GRIP DASH NUMBE R	DESIGN GRIP RANGE		OVERLAP MAX GRIP	-05 DIA.	-06 DIA.	-08 DIA.	-10 DIA.	-12 DIA.	
	MIN.	MAX.	$\triangle_6$	( L )	( L )	( L )	( L )	( L )	
-03	.126	.187	.195	.513	.544	.649	-	-	
-04	.188	.250	.258	.576	.607	.711	-	-	
-05	.251	.312	.320	.638	.669	.774	.854	-	
-06	.313	.375	.383	.701	.732	.836	.916	1.010	
-07	.376	.437	.445	.763	.794	.899	.979	1.073	
-08	.438	.500	.508	.826	.857	.961	1.041	1.135	
-09	.501	.562	.570	.888	.919	1.024	1.104	1.198	
-10	.563	.625	.633	.951	.982	1.086	1.166	1.260	
-11	.626	.687	.695	1.013	1.044	1.149	1.229	1.323	
-12	.688	.750	.758	-	1.107	1.211	1.291	1.385	
-13	.751	.812	.820	-	1.169	1.274	1.354	1.448	
-14	.813	.875	.883	-	1.232	1.337	1.416	1.510	
-15	.876	.937	.945	-	-	1.399	1.479	1.573	
-16	.938	1.000	1.008	-	-	-	1.541	1.635	
-17	1.001	1.062	1.070	-	-	-	1.604	1.698	
-18	1.063	1.125	1.133	-	-	-	1.666	1.760	
-19	1.126	1.187	1.195	-	-	-	1.729	1.823	
-20	1.188	1.250	1.258	-	-	-	1.791	1.885	

1. SINGLE SHEAR TESTING SHALL BE IN ACCORDANCE WITH THE REQUIREMENTS OF NASM 1312-20 AND APPLIES TO GRIPS 05-05 MIN, 06-06 MIN, 08-07 MIN, 10-09 MIN AND 12-10 MIN AND LONGER. TENSILE STRENGTH TESTING SHALL BE IN ACCORDANCE WITH REQUIREMENTS OF NASM 1312-8 AND APPLIES TO GRIPS 05-06 MAX, 06-07 MAX, 08-08 MAX, 10-10 MAX AND 12-12 MAX AND LONGER.
2. DIMENSIONS ARE IN INCHES AND ARE TO BE MET AFTER FINISH.
3. 3 INDENTATIONS 120° APART TO PROVIDE THREAD LOCK.
4. BLIND SIDE HEAD MAY BE INSTALLED ON 5° MAXIMUM SLOPE.
5. THE AVERAGE SMALLEST AND LARGEST OBSERVED VALUES ON THE SAME SPECIMEN SHALL BE EQUAL TO OR GREATER THAN THE STATED MINIMUM.
6. EXTENDED GRIP "BD MIN" VALUE APPLIES TO A PART DRIVEN .008" ± .002" ABOVE THE DESIGN MAXIMUM GRIP. SEE GRIP TABLE ON PAGE 2.
7. SLEEVE DIA. MAY BE UP TO .0003" OVERSIZE IN BAND ANNEAL ZONE. ZONE EXTENDS FROM APPROXIMATELY BLIND END - .470" FOR THE -05 DIA., - .525" FOR THE -06 DIA., -.635" FOR THE -08 DIA., - .700" FOR THE -10 DIA., - .750" FOR THE -12 DIA.

DIMENSIONS IN INCHES

<b>AC</b>	ECN 15069 - TABLE REFORMATTING		Current Design Activity CAGE Code 0HDW7		PROCUREMENT SPEC T0108	DRAWN BY J. SCHLOBOHM	
					CHECKED BY	SIGNATURE ON FILE	
ISSUED	05/15/2007	BLIND BOLT FASTENER, HIGH STRENGTH, FRICTION THREAD LOCK, THREADED, 100° FLUSH TENSION HEAD, CLOSE TOLERANCE SHANK, TITANIUM/A-286 (95 KSI SHEAR)				<b>ER213</b>	
REVISED	05/15/2022					<b>SK12822</b>	
PAGE	2 OF 4						

This drawing/documentation is controlled by either the Department of State, International Traffic In Arms Regulations or the Department of Commerce, Export Administration Regulations and may require an export license/license exception prior to being transferred to a foreign national, inside or outside of the United States. EAR/ECCN EAR99. These commodities, technology or software were exported from the United States in accordance with the Export Administration Regulations. Diversion contrary to U.S. law prohibited.

THIS DRAWING, THE STRUCTURAL DESIGN DISCLOSED THEREIN AND THE TECHNICAL DATA AND ENGINEERING SERVICE REPRESENTED THEREBY ARE THE EXCLUSIVE PROPERTY OF HUCK INTERNATIONAL, INC.



Howmet Fastening Systems  
 Tucson Operations  
 3724 East Columbia Street  
 Tucson, Arizona 85714 USA  
 Phone (520) 519-7400  
 Fax (520) 519-7454

**Ergo-Tech®**  
**BLIND BOLT**  
**ENGINEERING**  
**STANDARD**

**TABLE III** <sup>15.</sup>

FINISH CODE	MATERIAL		FINISH		PROCUREMENT SPECIFICATION
	NUT BODY	CORE BOLT	NUT BODY	CORE BOLT	
NONE	A286 CRES PER CHEMICAL COMPOSITION AMS 5737 OR AMS 5732	6Al-4V TITANIUM PER AMS 4967 OR AMS 4928	PASSIVATE PER AMS 2700 TYPE 2 OR TYPE 8	INCOTEC TEC-LUBE DRY FILM LUBE PER AS5272 OR EQUIVALENT	T0108
<sup>11.</sup>			IVD ALUMINUM COAT PER MIL- DTL-83488, TYPE II, CLASS 3 AND EN6118		
AC <sup>12.</sup> <sup>14.</sup>			CHROMATED ALUMINUM PIGMENTED COATING PER NAS4006 & EN4473, TYPE I, CLASS A		
ACN <sup>13.</sup> <sup>14.</sup>			NON-CHROMATED ALUMINUM PIGMENTED COATING PER NAS4006 AND EN4473		
ACP <sup>11.</sup>			CHROMATED ALUMINUM PIGMENTED COATING PER NAS4006 & EN4473		

**NUMBER KEY:**

ER213 - xx - xx xxx

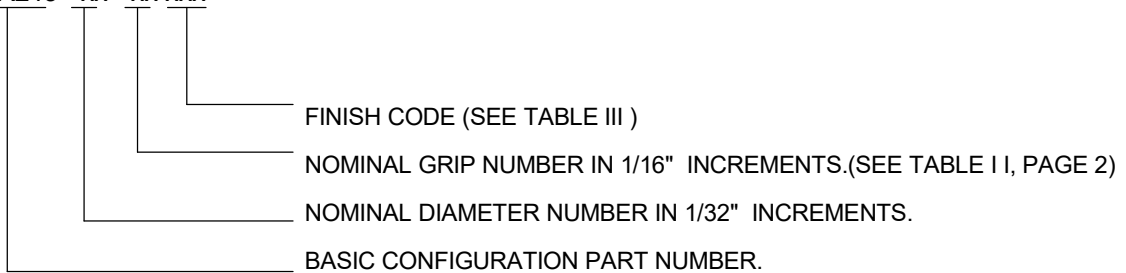

- <sup>8.</sup> IDENTIFICATION: -05 AND -06: MANUFACTURER'S ID. -08, -10 AND -12: MANUFACTURER'S ID AND AN OPTIONAL CIRCLE OR CIRCLE OUTLINE FOR ER213 HEAD CONFIGURATION. MARKING INDENTED .010 MAXIMUM, ARRANGEMENT OPTIONAL. -05 AND -06 PARTS MANUFACTURED WITHOUT MANUFACTURER'S ID MAY BE USED UNTIL STOCKS ARE DEPLETED.
- <sup>9.</sup> TRANSITION, OPTIONAL RADIUS OR CHAMFER.
- <sup>10.</sup> CONSULT HFS FOR AVAILABILITY OF LONGER GRIP LENGTHS
- <sup>11.</sup> THIS FINISH IS INACTIVE FOR NEW DESIGN AND PROCUREMENT. NO SUPERSESSIONS AVAILABLE.
- <sup>12.</sup> THIS FINISH IS INACTIVE FOR NEW DESIGN AND PROCUREMENT AFTER 03/01/2022.
- <sup>13.</sup> ACN FINISH IS SUPERSESSION FOR THE AC FINISH CODE
- <sup>14.</sup> NOTE: COMPLETE COVERAGE OF SLEEVE INTERNAL FEATURES IS NOT REQUIRED. OVERSPRAY ONTO THE INTERNAL FEATURES IS ACCEPTED.
- <sup>15.</sup> NOTE: CETYL ALCOHOL LUBE PER AS87132 MAY BE APPLIED TO COMPONENTS (AT MFR'S OPTION)

DIMENSIONS IN INCHES

<b>AC</b>	ECN 15069 - TABLE REFORMATTING		Current Design Activity CAGE Code 0HDW7		PROCUREMENT SPEC T0108	DRAWN BY J. SCHLOBOHM
					CHECKED BY	SIGNATURE ON FILE
ISSUED	05/15/2007	BLIND BOLT FASTENER, HIGH STRENGTH, FRICTION THREAD LOCK, THREADED, 100° FLUSH TENSION HEAD, CLOSE TOLERANCE SHANK, TITANIUM/A-286 (95 KSI SHEAR)			<b>ER213</b>	
REVISED	05/15/2022					
PAGE	3 OF 4				<b>SK12822</b>	

THIS DRAWING, THE STRUCTURAL DESIGN DISCLOSED THEREIN AND THE TECHNICAL DATA AND ENGINEERING SERVICE REPRESENTED THEREBY ARE THE EXCLUSIVE PROPERTY OF HUCK INTERNATIONAL, INC.

*This drawing/documentation is controlled by either the Department of State, International Traffic In Arms Regulations or the Department of Commerce, Export Administration Regulations and may Require an export license/license exception prior to being transferred to a foreign national, inside or outside of the United States. EAR/ECCN EAR99. These commodities, technology or software were exported from the United States in accordance with the Export Administration Regulations. Diversion contrary to U.S. law prohibited.*



Howmet Fastening Systems  
 Tucson Operations  
 3724 East Columbia Street  
 Tucson, Arizona 85714 USA  
 Phone (520) 519-7400  
 Fax (520) 519-7454

**Ergo-Tech<sup>®</sup>**  
**BLIND BOLT**  
**ENGINEERING**  
**STANDARD**

**TABLE I V**

INSTALLED WEIGHT (LBS/1000)			
DIAMETER	GRIP	WEIGHT	ADDER
-05 (.164)	-03	2.45	.259
-06 (.190)	-03	3.58	.349
-08 (.250)	-03	7.82	.598
-10 (.313)	-05	15.57	.938
-12 (.375)	-06	26.77	1.355

THIS DRAWING, THE STRUCTURAL DESIGN DISCLOSED THEREIN AND THE TECHNICAL DATA AND ENGINEERING SERVICE REPRESENTED THEREBY ARE THE EXCLUSIVE PROPERTY OF HUCK INTERNATIONAL, INC.

DIMENSIONS IN INCHES

<b>AC</b>	ECN 15069 - TABLE REFORMATTING		Current Design Activity CAGE Code 0HDW7		PROCUREMENT SPEC T0108	DRAWN BY J. SCHLOBOHM
	ISSUED	05/15/2007	BLIND BOLT FASTENER, HIGH STRENGTH, FRICTION THREAD LOCK, THREADED, 100° FLUSH TENSION HEAD, CLOSE TOLERANCE SHANK, TITANIUM/A-286 (95 KSI SHEAR)			CHECKED BY
REVISED	05/15/2022	<b>ER213</b>				
PAGE	4 OF 4	<b>SK12822</b>				

*This drawing/documentation is controlled by either the Department of State, International Traffic In Arms Regulations or the Department of Commerce, Export Administration Regulations and may require an export license/license exception prior to being transferred to a foreign national, inside or outside of the United States. EAR/ECCN EAR99. These commodities, technology or software were exported from the United States in accordance with the Export Administration Regulations. Diversion contrary to U.S. law prohibited.*