

RD J 306 SB 8 L
 ROSAN INSERT, C'BORED
 AS8879 INTERNAL THREAD
 SERIES NUMBER (THREAD COMBINATION)
 INTERNAL THREAD LOCKING FEATURE (LEAVE BLANK FOR NON-LOCK)
 "C" LENGTH IN 1/16" INCREMENTS
 MATERIAL CODE <1>

TABLE I

INSERT PART NUMBER	LOCKRING		A INTERNAL THREAD UNJF-3B	B EXTERNAL THREAD <2>			C ±.015	D ±.015	E ±.005	F ±.005
	INSERT PART NUMBER <3>	MILITARY PART NUMBER <3>		SIZE	PITCH DIA	MINOR DIA				
RDJ302()4	RLRR16SB5	MS51990-102P	.1120-48	.1900-32	.1699-.1714	.1475-.1534	.250	.150	.040	.113
RDJ303()5	RLRR18SB6	MS51990-103P	.1380-40	.2160-28	.1931-.1946	.1674-.1740	.310	.190	.040	.140
RDJ304()6	RLRR21SB6	MS51990-104P	.1640-36	.2500-28	.2271-.2286	.2014-.2080	.380	.250	.047	.166
RDJ305()7	RLRR24SB7	MS51990-105P	.1900-32	.3125-24	.2858-.2873	.2559-.2632	.440	.290	.062	.196
RDJ306()8	RLRR28SB8	MS51990-106P	.2500-28	.3750-24	.3479-.3498	.3185-.3257	.500	.330	.080	.257
RDJ307()9	RLRR31SB9	---	.3125-24	.4375-20	.4053-.4073	.3700-.3784	.560	.380	.095	.323
RDJ308()10	RLRR38SB9	MS51990-108P	.3750-24	.5000-20	.4678-.4698	.4325-.4409	.620	.420	.100	.386
RDJ309()11	RLRR47SB10	MS51990-109P	.4375-20	.6250-18	.5894-.5914	.5498-.5593	.690	.460	.100	.453
RDJ310()12	RLRR56SB11	MS51990-110P	.5000-20	.7500-16	.7097-.7122	.6656-.6761	.750	.490	.109	.516
RDJ311()14	RLRR64SB11	MS51990-111P	.5625-18	.8750-14	.8291-.8316	.7786-.7904	.880	.620	.125	.578
RDJ312()16	RLRR72SB11	MS51990-112P	.6250-18	1.0000-14	.9541-.9566	.9036-.9154	1.000	.740	.140	.640
RDJ313()18	RLRR82SB12	MS51990-113P	.7500-16	1.1250-12	1.0716-1.0741	1.0128-1.0260	1.120	.800	.156	.765
RDJ314()20	RLRR90SB12	MS51990-114P	.8750-14	1.2500-12	1.1966-1.1991	1.1378-1.1510	1.250	.900	.178	.890

NOTES:

- <1> FOR MATERIAL, HEAT TREAT AND FINISH CALLOUTS, SEE TABLE II.
- <2> THE EXTERNAL THREAD HAS A SPECIAL PITCH DIAMETER AND MINOR DIAMETER WHICH INSTALLS INTO A AS8879 CLASS 3B, FED-STD-H28/2 CLASS 3B, OR NATIONAL CLASS 3 TAPPED HOLE.
- <3> MATING LOCKRING IS NOT INCLUDED WITH INSERT. IT MUST BE ORDERED SEPARATELY.

MANUFACTURE OF THE PROPRIETARY PARTS SHOWN HERE WITHOUT WRITTEN CONSENT OF HOWMET FASTENING SYSTEMS IS ABSOLUTELY PROHIBITED.

THIS DRAWING EMBODIES A CONFIDENTIAL, PROPRIETARY DESIGN & ALL DESIGN, MANUFACTURING, PRODUCTION, USE & SALE RIGHTS REGARDING SAME ARE EXPRESSLY RESERVED.

APPROVED DATE 08/24/07	CURRENT DESIGN ACTIVITY: Howmet Fastening Systems (HFS)	TITLE: INSERT - RINGLOCKED, WITH C'BORE FINE INTERNAL AND EXTERNAL THREADS	CURRENT DESIGN ACTIVITY: CAGE CODE: 83324
REV. LETTER AND DATE B 3/17/23	TOLERANCE OPERATIONS Rosan Products 3018 W. Lomita Blvd. Torrance, California 90505-5103	UNLESS OTHERWISE SPECIFIED DIMENSIONS ARE IN INCHES & ASME Y14.5M TOLERANCES:	SALES DRAWING NO.
DAF NUMBER 122160		ANGLES = ±3° DECIMALS .XX = ±.02 .XXX = ±.010	RDJ300() (L) SERIES
			SHEET 1 OF 4



MANUFACTURE OF THE PROPRIETARY PARTS SHOWN HERE WITHOUT WRITTEN CONSENT OF HOWMET FASTENING SYSTEMS IS ABSOLUTELY PROHIBITED.

THIS DRAWING EMBODIES A CONFIDENTIAL PROPRIETARY DESIGN & ALL DESIGN, MANUFACTURING PRODUCTION, USE & SALE RIGHTS REGARDING SAME ARE EXPRESSLY RESERVED.

TABLE II

INSERT					
CODE	MATERIAL	SPECIFICATION	HEAT TREAT	FINISH WITHOUT INTERNAL THREAD LOCKING FEATURE	FINISH WITH INTERNAL THREAD LOCKING FEATURE
SA <4>	4130 STEEL	AMS-S-6758, CONDITION F	125 KSI UTS MIN	CAD PLATE PER AMS-QQ-P-416, TYPE II, CL ASS 3	CAD PLATE PER AMS-QQ-P-416, TYPE II, CL ASS 3
SB <4>	1117 STEEL	ASTM-A-108	NONE		
SF	17-4PH CRES	AMS 5643	COND H1025	PASSIVATE PER AMS 2700	PASSIVATE PER AMS 2700 PLUS SOLID FILM LUBE
SM <4>	303 CRES	ASTM-A-582 OR AMS 5640	NONE		
SN	4340 STEEL ALTERNATE: 4140 STEEL	MIL-S-5000 OR AMS-S-5625	160-180 KSI UTS	CAD PLATE PER AMS-QQ-P-416, TYPE II, CL ASS 3	CAD PLATE PER AMS-QQ-P-416, TYPE II, CL ASS 3
SU <4>	A286 CRES	AMS 5731, AMS 5732, AMS 5737 OR AMS5734	83 HRB MIN <5>	PASSIVATE PER AMS 2700	PASSIVATE PER AMS 2700 PLUS SOLID FILM LUBE PER AS5272
TA	6Al-4V TITANIUM	MIL-T-9047 CONDITION A OR AMS 4967	130 KSI UTS MIN	NONE	<6>
TB	6Al-4V TITANIUM	AMS 4967	160 KSI UTS MIN	NONE	<6>

NOTES: (CONTINUED)

- <4> NOTED CODES INDICATE STANDARD MATERIALS.
- <5> FOR A286 HEAT TREATED TO 130 KSI UTS MIN, ADD SUFFIX EO349 TO INSERT PART NUMBER.
- <6> INTERNAL THREAD LOCKING FEATURE NOT AVAILABLE AT THIS TIME.
- 7. FOR 1117 STEEL CASE HARDENED TO 50-60 HRC, ADD SUFFIX EO238 TO LOCKRING PART NUMBER.

APPROVED DATE 08/24/07	CURRENT DESIGN ACTIVITY: Howmet Fastening Systems (HFS)	TITLE: INSERT - RINGLOCKED, WITH C'BORE FINE INTERNAL AND EXTERNAL THREADS	CURRENT DESIGN ACTIVITY: CAGE CODE: 83324
REV. LETTER AND DATE B 3/17/23	TORRANCE OPERATIONS	UNLESS OTHERWISE SPECIFIED DIMENSIONS ARE IN INCHES & ASME Y14.5M TOLERANCES:	SALES DRAWING NO.
DAF NUMBER 122160	Rosan Products 3018 W. Lamita Blvd. Torrance, California 90505-5103	ANGLES = ±5° DECIMALS .XX = ±.02 .XXX = ±.010	RDJ300()()(L) SERIES
			SHEET 2 OF 4



MANUFACTURE OF THE PROPRIETARY PARTS SHOWN HERE WITHOUT WRITTEN CONSENT OF HOWMET FASTENING SYSTEMS IS ABSOLUTELY PROHIBITED.

THIS DRAWING EMBODIES A CONFIDENTIAL PROPRIETARY DESIGN & ALL DESIGN, MANUFACTURING PRODUCTION, USE & SALE RIGHTS REGARDING SAME ARE EXPRESSLY RESERVED.

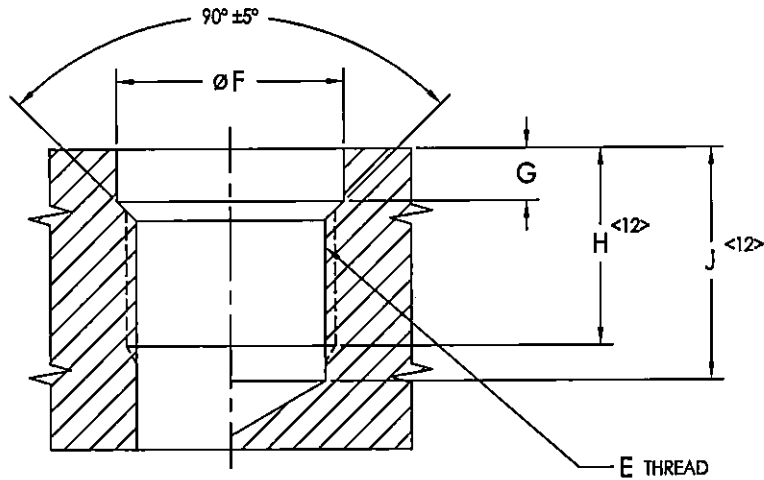

TABLE III

INSERT PART NUMBER REF	E THREAD CLASS 3B <10>	ØF +.003 -.000 <8>		G +.030 -.000	H MIN FULL THREAD DEPTH <12>	J MIN DRILL DEPTH <12>	
		AL	MAG			PLUG TAP	BOTTOM TAP
RDJ302()4	.1900-32UNJF	.250	.258	.094	.285	.426	.363
RDJ303()5	.2160-28UNJF	.281	.291	.109	.345	.506	.434
RDJ304()6	.2500-28UNJF	.328	.337	.109	.415	.576	.504
RDJ305()7	.3125-24UNJF	.375	.381	.141	.475	.663	.579
RDJ306()8	.3750-24UNJF	.437	.448	.156	.535	.723	.639
RDJ307()9	.4375-20UNJF	.484	.495	.172	.595	.820	.720
RDJ308()10	.5000-20UNJF	.593	.601	.172	.655	.880	.780
RDJ309()11	.6250-18UNJF	.734	.747	.188	.725	.975	.864
RDJ310()12	.7500-16UNJF	.875	.888	.203	.785	1.066	.941
RDJ311()14	.8750-14UNJF	1.000	1.015	.203	.915	1.236	1.094
RDJ312()16	1.0000-14UNJS	1.125	1.139	.203	1.035	1.356	1.214
RDJ313()18	1.1250-12UNJF	1.281	1.298	.219	1.155	1.530	1.363
RDJ314()20	1.2500-12UNJF	1.406	1.427	.219	1.285	1.660	1.493

NOTES: (CONTINUED)

- <8> "F" DIAMETER AND MINOR DIAMETER OF THREAD TO BE CONCENTRIC WITHIN .003 FIM.
- 9. WHEN PARENT MATERIAL SURFACE IS NOT FLAT OR NORMAL TO AXIS OF HOLE, PROVIDE A SPOTFACE FOR PROPER LOCKRING ENTRY.
- <10> THREAD AS SHOWN PER AS8879 IS PREFERRED. ALTERNATE THREAD PER FED-STD-H28/2 CLASS 3B OR NATIONAL CLASS 3 IS APPLICABLE WHEN SPECIFIED BY DESIGN ACTIVITY.
- 11. REMOVE ALL BURRS AND SHARP EDGES.
- <12> "H" MINIMUM FULL THREAD DEPTH AND "J" MINIMUM DRILL DEPTH ARE APPLICABLE FOR STANDARD INSERT LENGTH SHOWN ONLY. FOR NON-STANDARD LENGTHS (SEE PART NUMBER CODING) "H" AND "J" MUST CHANGE ACCORDINGLY.

APPROVED DATE 08/24/07	CURRENT DESIGN ACTIVITY: Howmet Fastening Systems (HFS)	TITLE: INSERT - RINGLOCKED, WITH C'BORE FINE INTERNAL AND EXTERNAL THREADS	CURRENT DESIGN ACTIVITY: CAGE CODE: 83324
REV. LETTER AND DATE B 3/17/23	TORRANCE OPERATIONS		SALES DRAWING NO.
DAF NUMBER 122160	Rosan Products 3018 W. Lomita Blvd. Torrance, California 90505-5103	UNLESS OTHERWISE SPECIFIED DIMENSIONS ARE IN INCHES & ASME Y14.5M TOLERANCES:	RDJ300() (L) SERIES SHEET 3 OF 4



MANUFACTURE OF THE PROPRIETARY PARTS SHOWN HERE WITHOUT WRITTEN CONSENT OF HOWMET FASTENING SYSTEMS IS ABSOLUTELY PROHIBITED.

THIS DRAWING EMBODIES A CONFIDENTIAL, PROPRIETARY DESIGN & ALL DESIGN, MANUFACTURING PRODUCTION, USE & SALE RIGHTS REGARDING SAME ARE EXPRESSLY RESERVED.

TABLE IV

INSERT PART NUMBER REF	STEP DRILL PART NUMBER <13>		BASIC TAP SIZE <14> REF	WRENCH PART NUMBER	LOCKRING DRIVE TOOL PART NUMBER	REMOVAL DRILL SIZE <15> REF
	ALUMINUM	MAGNESIUM				
RDJ302()4	RCDC16-159	RCADC16-159	.1900-32UNF	R1102W	R102D	7/32
RDJ303()5	RCDC18-180	RCADC18-180	.2160-28UNF	R1103W	R103D	1/4
RDJ304()6	RCDC21-213	RCADC21-213	.2500-28UNF	R1104W	R104D	19/64
RDJ305()7	RCDC24-272	RCADC24-272	.3125-24UNF	R1105W	R205D	F
RDJ306()8	RCDC28-332	RCADC28-332	.3750-24UNF	R1106W	R206D	5/16
RDJ307()9	RCDC31-386	RCADC31-386	.4375-20UNF	R1107W	R207D	U
RDJ308()10	RCDC38-453	RCADC38-453	.5000-20UNF	R1108W	R208D	29/64
RDJ309()11	RCDC47-569	RCADC47-569	.6250-18UNF	R1110W	R209D	9/16
RDJ310()12	RCDC56-687	RCADC56-687	.7500-16UNF	R1111W	R210D	11/16
RDJ311()14	RCDC64-802	RCADC64-802	.8750-14UNF	R1112W	R211D	25/32
RDJ312()16	RCDC72-927	RCADC72-927	1.0000-14UNS	R1113W	R212D	57/64
RDJ313()18	RCDC82-1043	RCADC82-1043	1.1250-12UNF	R1114W	R213D	1 1/32
RDJ314()20	RCDC90-1165	RCADC90-1165	1.2500-12UNF	R1115W	R214D	1 11/64

NOTES: (CONTINUED)

- <13> STEP DRILLS ARE DESIGNED FOR THRU HOLE DRILLING. WHEN USED TO DRILL A BLIND HOLE, IT MAY BE NECESSARY TO GRIND THE DRILL TO SUIT THE DEPTH REQUIRED.
- <14> TAPS ARE NOT SUPPLIED BY ALCOA.
- <15> REMOVAL DRILLS ARE NOT SUPPLIED BY ALCOA.

APPROVED DATE 08/24/07	CURRENT DESIGN ACTIVITY: Howmet Fastening Systems (HFS) TORRANCE OPERATIONS	TITLE: INSERT - RINGLOCKED, WITH C'BORE FINE INTERNAL AND EXTERNAL THREADS	CURRENT DESIGN ACTIVITY: CAGE CODE: 83324
REV. LETTER AND DATE B 3/17/23	Rosan Products 3018 W. Lomita Blvd. Torrance, California 90505-5103	UNLESS OTHERWISE SPECIFIED DIMENSIONS ARE IN INCHES & ASME Y14.5M TOLERANCES:	SALES DRAWING NO. RDJ300() () (L) SERIES
DAF NUMBER 122160		ANGLES DECIMALS " ±.3" XX ±.02 .XXX ±.010	SHEET 4 OF 4