

NOTES: UNLESS OTHERWISE SPECIFIED:

1. ASSEMBLY PROCEDURES:
 - 1.1 INSTALL STUD NUT THRU $\phi .250-.255$ HOLE.
 - 1.2 INSTALL CA1825-1 RETAINING ON STUD.
 - 1.3 PRESS CA18014 CAGE INTO $\phi .498-.502$ C'BORE.
2. CONSULT TRIDAIR'S ENGINEERING DEPARTMENT FOR A AVAILABILITY OF OPTIONAL MATERIALS FINISHES AND SIZES.
3. MATERIAL: 300 SERIES CRES, PER ASTM A484, ASTM A581 AND AMS5640.
4. FINISH:
 - 4.1 PASSIVATE PER AMS-QQ-P-35 OR OPTIONAL FINISH OF CADMIUM PLATE PER AMS-QQ-P-416, TYPE II, CLASS 2. (SEE NOTE 4 FOR PART NUMBER EXAMPLE).
5. PART NUMBER CALLOUT:
 - CA18014
 └── BASIC PART NUMBER, PASSIVATE FINISH
 - CA18014 C
 └── DESIGNATES CADMIUM PLATE FINISH
 - └── BASIC PART NUMBER
6. DIMENSIONS APPLY BEFORE CADMIUM PLATE FOR CA18014C PART.

REPRODUCTION OF THIS DRAWING OR MANUFACTURE OF THE PROPRIETARY PARTS SHOWN HERE WITHOUT WRITTEN CONSENT OF FAIRCHILD AEROSPACE FASTENER DIVISION IS ABSOLUTELY PROHIBITED. THIS DRAWING EMBODIES A CONFIDENTIAL PROPRIETARY DESIGN & ALL DESIGN MANUFACTURING PRODUCTION, USE & SALE RIGHTS REGARDING SAME ARE EXPRESSLY RESERVED.

UNLESS OTHERWISE SPECIFIED DIMENSIONS ARE IN INCHES & ASME Y14.5M-94 TOLERANCES:

ANGLES = $\pm 1^\circ$
 FRACTIONS = $\pm 1/32$
 DECIMALS .XX = $\pm .02$
 .XXX = $\pm .010$

PROJECT NO. 03-009
S45008

APPROVED DATE	7 FEB 79
REV. LETTER AND DATE	G 23 SEP 02 <i>GA</i>
DAF NUMBER	DAF 56505



AEROSPACE FASTENER DIVISION
 3000 West Lomita Boulevard
 Torrance, Ca 90505

CAGE CODE: 29372

TRIDAIR PRODUCT

- CAGE -
STUD NUT HOLD OUT

CA18014

SHEET 1 OF 2

SALES

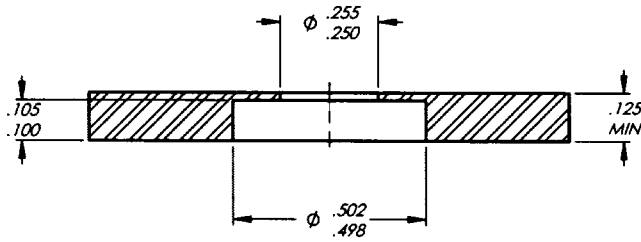

TYPICAL INSTALLATION
FOR CA1821 STUD NUT

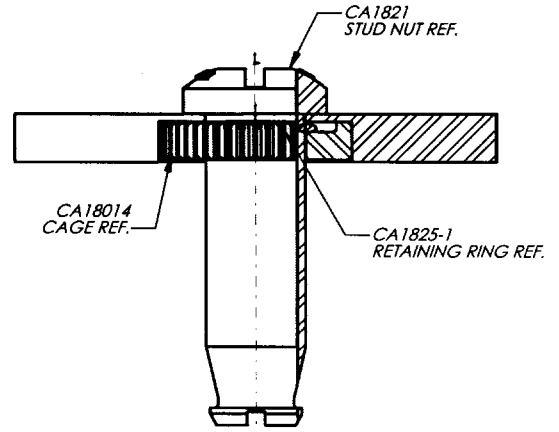

TYPICAL INSTALLATION

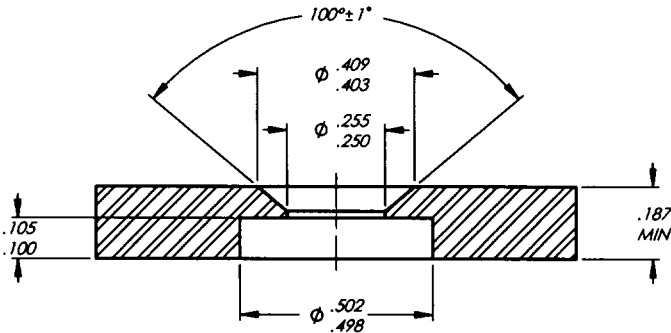

TYPICAL INSTALLATION
FOR CA1832 STUD NUT

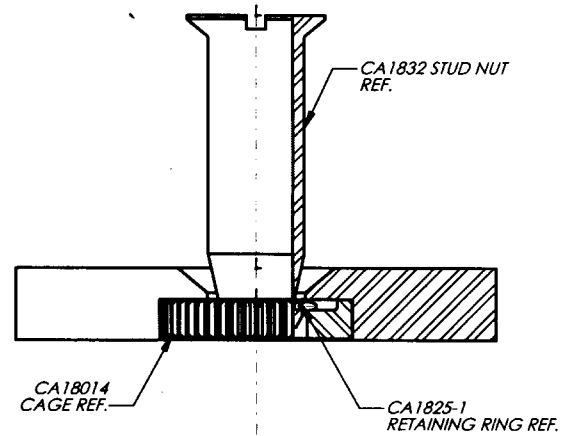

TYPICAL INSTALLATION
SHOWN HOLD OUT POSITION

REPRODUCTION OF THIS DRAWING OR MANUFACTURE OF THE PROPRIETARY FASTENER DIVISION IS ABSOLUTELY PROHIBITED. THIS DRAWING EMBODIES A CONFIDENTIAL PROPRIETARY DESIGN & ALL DESIGN MANUFACTURING PRODUCTION, USE & SALE RIGHTS REGARDING SAME ARE EXPRESSLY RESERVED.

PROJECT NO. 03-009
S45008

UNLESS OTHERWISE SPECIFIED
DIMENSIONS ARE IN INCHES &
ASME Y14.5M-94 TOLERANCES:

ANGLES = ±1°
FRACTIONS = ±1/32
DECIMALS .XX = ±.02
.XXX = ±.010

APPROVED DATE

7 FEB 79

REV. LETTER AND DATE

F 21 AUG 02

DAF NUMBER

DAF 56173

Fairchild Fasteners

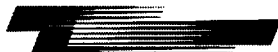

AEROSPACE FASTENER DIVISION

3000 West Lomita Boulevard
Torrance, Ca 90505

CAGE CODE: 29372

TRIDAIR PRODUCT

- CAGE -
STUD NUT HOLD OUT

CA18014

SHEET 2 OF 2

SALES