

Details of form, not stated, are at the manufacturer's option.

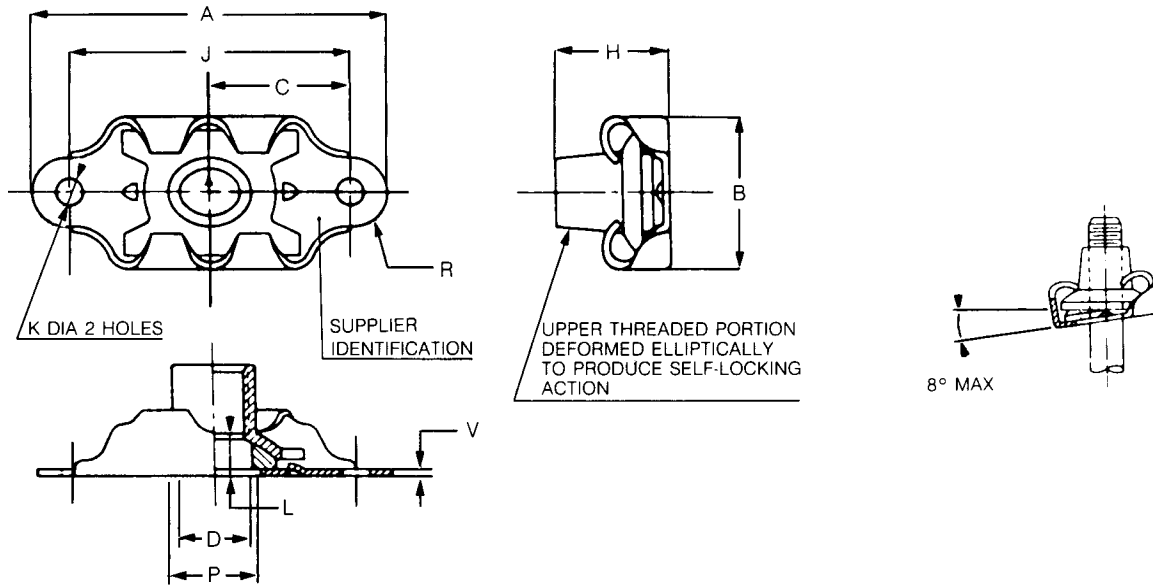

PART NUMBER	THREAD	A	B	C	D	H	J	K	L	P	R	V	Ultimate Tensile Strength LB/Min.	Approx. Weight LB/100
		Max.	Max.	±.005	Min.	Max.	±.002	+ .005 + .000	Min.	Min.	Min.	Ref.		
LAONM53M	.1900-32 UNJF-3B	.912	.500	.344	.194	.322	.688	.098	.125	.250	.095	.031	2460	.84
LAONM54M	.2500-28 UNJF-3B	1.265	.562	.500	.254	.406	1.000	.098	.141	.311	.100	.031	4580	1.48
LAONM55M	.3125-24 UNJF-3B	1.291	.735	.500	.317	.469	1.000	.130	.188	.374	.125	.031	7390	3.33

Contact Howmet Fastening Systems for the diameter/type in manufacturing.

■ Dimensions in Inch.

MATERIAL:	Nut and spherical washer: A286 per AMS5525, AMS5732, AMS5737.
HARDNESS:	ROCKWELL 49 maximum.
FINISH:	Dry film lubricant. Optional dry film lubricant on nut retaining cage and spherical washer.
PERFORMANCE:	In accordance with NASM25027.
THREADS:	In accordance with AS8879 before lubrication.
FLOATABILITY:	.025 radially from center.
MISALIGNMENT:	8° in any direction from centered position.
VARIATION:	Add « K » for bottom c'sunk rivet holes, for example : LAONM53MK.
APPLICATION:	Type LAONM nuts are two lug, self aligning anchor nuts designed for use in shear or tensile applications involving temperatures up to 450° F. The LAONM features a self aligning design which qualifies it for use in applications involving not only radial but vertical misalignment of bolts at assembly to the limitations designed. Added advantages areas also provided in weight and stock savings on shims and bolts due to the flexibility in thread length provided by the counterbore to permit use of either full or shear thread length bolts.
MARKING:	Parts marked with manufacturer's symbol (SD), plus letter "C".