

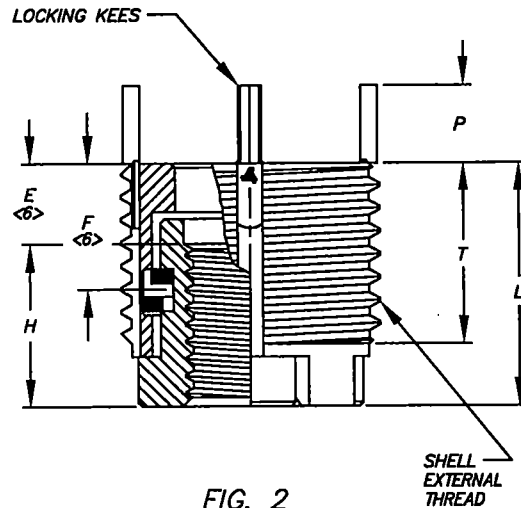

MANUFACTURE OF THE PROPRIETARY PARTS SHOWN HERE WITHOUT WRITTEN CONSENT OF HOWMET FASTENING SYSTEMS IS ABSOLUTELY PROHIBITED.

THIS DRAWING ENRODES A CONFIDENTIAL, PROPRIETARY DESIGN & ALL DESIGN, MANUFACTURING PRODUCTION, USE & SALE RIGHTS REGARDING SAME ARE EXPRESSLY RESERVED.

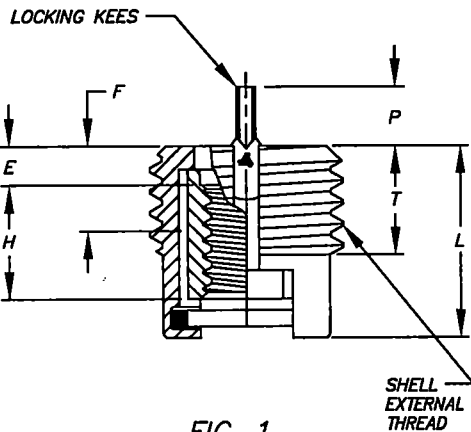
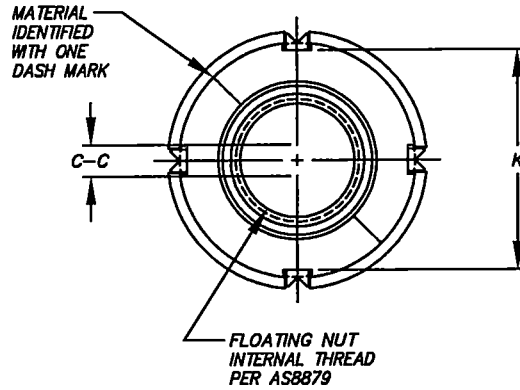
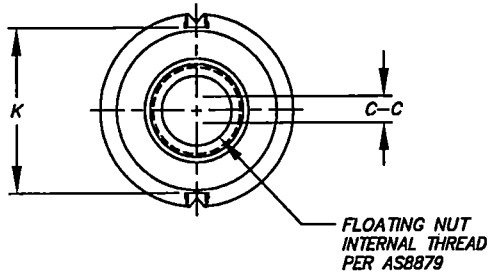

**FIG. 1**

FOR SIZE CODES  
0256 THRU 0832, 524 AND 518  
(KNK SERIES)

**FIG. 2**

FOR SIZE CODES  
1032 THRU 420, 624 AND 616  
(KNKD SERIES)

**TABLE 1**

SIZE CODE	FIG NO	INTERNAL THREAD AS8879	EXTERNAL THREAD	MODIFIED MINOR DIA ±.004	L ±.015	E TO 1ST THREAD <6>	H INTERNAL THREAD LENGTH	C-C FLOAT MIN	T EXTERNAL THREAD LENGTH	KEES		K REF	F TO LOCK CENTER <6>
										QTY	P REF		
0256	1	.086-56UNJC-3B	.2500-28UNF-2A (MOD)	.213	.19	.05	.10	.015	.11	2	.060	.196	.11
0440	1	.112-40UNJC-3B	.3125-24UNF-2A	STD	.32	.07	.21	.020	.19	2	.110	.220	.16
0632	1	.138-32UNJC-3B	.3750-24UNF-2A	STD	.36	.08	.22	.030	.21	2	.125	.286	.19
0832	1	.164-32UNJC-3B	.3750-24UNF-2A	STD	.36	.08	.22	.030	.21	2	.125	.286	.19
1032	2	.190-32UNJF-3B	.4375-20UNF-2A (MOD)	.396	.40	.15	.25	.040	.29	2	.156	.356	.24
1024	2	.190-24UNJC-3B	.4375-20UNF-2A (MOD)	.396	.40	.15	.25	.040	.29	2	.156	.356	.24
428	2	.250-28UNJF-3B	.5000-20UNF-2A (MOD)	.458	.40	.15	.25	.040	.29	2	.156	.416	.27
420	2	.250-20UNJC-3B	.5000-20UNF-2A (MOD)	.458	.40	.15	.25	.040	.29	2	.156	.416	.27
524	1	.3125-24UNJF-3B	.6250-18UNF-2A (MOD)	.570	.53	.13	.39	.040	.38	4	.187	.532	.26
518	1	.3125-18UNJC-3B	.6250-18UNF-2A (MOD)	.570	.53	.13	.39	.040	.38	4	.187	.532	.26
624	2	.375-24UNJF-3B	.7500-16UNF-2A (MOD)	.686	.65	.20	.45	.040	.51	4	.187	.659	.39
616	2	.375-16UNJC-3B	.7500-16UNF-2A (MOD)	.686	.65	.20	.45	.040	.51	4	.187	.659	.39

APPROVED DATE 09/25/96	CURRENT DESIGN ACTIVITY: Howmet Fastening Systems (HFS) TORRANCE OPERATIONS	TITLE: <b>KEENSERT, FLOATING INSERT</b>	CURRENT DESIGN ACTIVITY: CAGE CODE: 29372 SALES DRAWING NO.
REV. LETTER AND DATE L 06/02/20 CA	<b>Tridair Products</b> 3000 W. Lomita Blvd. Torrance, California 90505	UNLESS OTHERWISE SPECIFIED DIMENSIONS ARE IN INCHES & ASME Y14.5M TOLERANCES:	<b>KNK(D)(L)(JT)</b>
DAF NUMBER 119447		ANGLES = ±3' DECIMALS .XX = ±.02 XXX = ±.010	SHEET 1 OF 2

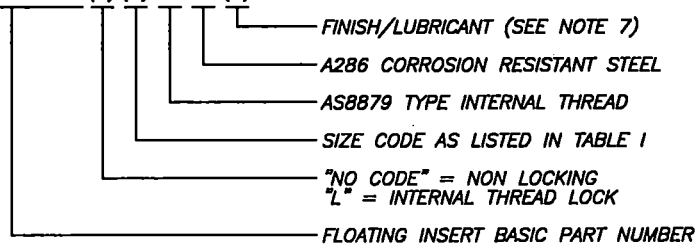

**TABLE II**

SIZE CODE	INSTALLATION DATA					REMOVAL DATA	
	TAP DRILL DIA	C'SINK DIA +.010 -.000	THREAD TAP		INSTALLATION TOOL PART NUMBER	DRILL	
			SIZE UNF-2B	MIN DEPTH FULL THD		SIZE	DEPTH
0256	.227-.231	.250	.2500-28	.12	TK 02	#8 (.199)	3/32
0440	.270-.276	.323	.3125-24	.31	TK 04	7/32	1/8
0632	.331-.336	.385	.3750-24	.38	TK 06	9/32	1/8
0832	.331-.336	.385	.3750-24	.38	TK 08	9/32	1/8
1032	.405-.410	.447	.4375-20	.39	TK 010	11/32	5/32
1024	.405-.410	.447	.4375-20	.39	TK 010	11/32	5/32
428	.467-.472	.510	.5000-20	.39	TK 4	13/32	5/32
420	.467-.472	.510	.5000-20	.39	TK 4	13/32	5/32
524	.577-.583	.635	.6250-18	.50	TK 5	17/32	3/16
518	.577-.583	.635	.6250-18	.50	TK 5	17/32	3/16
624	.702-.708	.760	.7500-16	.62	TK 6	21/32	3/16
616	.702-.708	.760	.7500-16	.62	TK 6	21/32	3/16

**PART NUMBER CODE:**

KNK OR KNKD ( ) ( ) J T ( )



**NOTES:**

1. MATERIAL:
  - 1.1 NUT AND SHELL: A286 CRES PER AMS 5732 OR AMS 5737.
  - 1.2 LOCKING KEES: 302 CRES PER ASTM A580 (CHEMISTRY ONLY).
  - 1.3 RETAINING RINGS: 302 CRES PER ASTM A580 OR ASTM A313 (CHEMISTRY ONLY).
2. HEAT TREAT:
  - 2.1 140 KSI MIN PER AMS 2759.
3. FINISH:
  - 3.1 SHELL & NUT: PASSIVATE PER AMS 2700.
  - 3.2 LOCKING KEES & RETAINING RINGS: PASSIVATE PER AMS 2700.
4. LUBRICATION: DRY FILM LUBRICANT PER AS5272, TYPE I (APPLIED TO NUT COMPONENT OF SELF-LOCKING INSERTS).
5. INTERNAL THREAD LOCK, TENSILE, PUSH-OUT, AND TORQUE-OUT SHALL BE PER NASM25027.
- <6> DISTANCE TO FIRST INTERNAL THREAD AND DISTANCE TO INTERNAL THREAD LOCK MEASURED WITH NUT IN RETAINED POSITION.
- <7> CODE AFTER PART NUMBER INDICATES THE FOLLOWING OPTIONS:
  - "DFL": DRY FILM LUBE REQUIRED ON NON-LOCKING NUTS.
  - "ESL": ESNALUBE #382.
  - "SP": SILVER PLATE PER ASTM B700.
  - "NE": NO DRY FILM LUBE.
8. FOR ADDITIONAL CODES, REFER TO S-70248.
9. INSTALLATION PROCEDURE:
  - 9.1 PREPARE PANEL PER THE DIMENSIONS IN TABLE II.
  - 9.2 SCREW IN INSERT WITH FINGERS OR INSTALLATION TOOL. INSERT IS DESIGNED TO STOP AT CORRECT DEPTH.
  - 9.3 DRIVE LOCKING KEES DOWN USING THE INSTALLATION TOOL.
10. REMOVAL PROCEDURE:
  - 10.1 USE DRILL SIZE AND DEPTH SPECIFIED IN TABLE II TO REMOVE MATERIAL BETWEEN LOCKING KEES.
  - 10.2 DEFLECT LOCKING KEES INWARD AND BREAK OFF.
  - 10.3 REMOVE INSERT WITH AN "EASY-OUT" TYPE TOOL.

MANUFACTURE OF THE PROPRIETARY PARTS SHOWN HERE WITHOUT WRITTEN CONSENT OF HOWMET FASTENING SYSTEMS IS ABSOLUTELY PROHIBITED.

THIS DRAWING EMBODIES A CONFIDENTIAL, PROPRIETARY DESIGN & ALL DESIGN, MANUFACTURING PRODUCTION, USE & SALE RIGHTS REGARDING SAME ARE EXPRESSLY RESERVED.

APPROVED DATE 09/25/96	CURRENT DESIGN ACTIVITY Howmet Fastening Systems (HFS)	TITLE: <b>KEENSERT, FLOATING INSERT</b>	CURRENT DESIGN ACTIVITY CAGE CODE: 29372
REV. LETTER AND DATE L 06/02/2006	TORRANCE OPERATIONS <b>Tridair Products</b> 3000 W. Lamita Blvd. Torrance, California 90505	UNLESS OTHERWISE SPECIFIED DIMENSIONS ARE IN INCHES & ASME Y14.5M TOLERANCES	SALES DRAWING NO. <b>KNK(D)(L)( )JT( )</b>
DAF NUMBER 119447		ANGLES = ±3° DECIMALS .XX = ±.02 .XXX = ±.010	SHEET 2 OF 2