



ARCONIC

# KEENSERTS® Inserts Installation, Removal & Broach

One-piece KEENSERTS® Inserts are supplied with keys pre-assembled into dove-tailed slots at the factory, to eliminate the problems of selecting, stocking and assembling separate parts. The pre-positioned keys automatically set the insert at the proper depth below the surface of the parent material. Unlike conventional inserts, there is no need to maintain critical depth tolerances — no chance of inadequate locking or deformation of internal threads due to miscalculations of depth. For critical edge distance applications, please consult our Customer Applications Engineers.

## Insert Installation

1. **Drill** with a **standard** drill, as listed for each part number.
2. **Countersink** with a **standard** countersink (82° to 100°).
3. **Tap** with a **standard** Unified Thread Series tap.

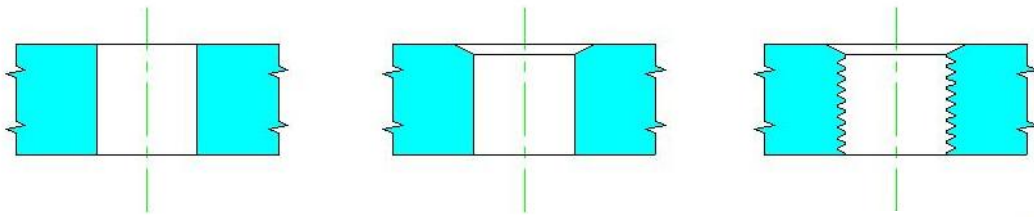

4. Screw in insert with fingers or installation tool. Insert is designed to stop at the correct depth below the surface of the casting.
5. Using the installation tool, drive in the keys. The tool may be used with a hammer or held in an arbor press. The correct insert tool is tabulated with each type of insert in this catalog.

### Notes:

- For Miniature Series inserts, screw the insert onto the threaded mandrel and turn the insert into the tapped hole.
- When the tool handle is depressed, a special spring loaded trip mechanism within the tool will drive the KEES into the parent material.
- The replacement of inserts is accomplished without reworking the parent material, and the same size insert is used in the original hole.

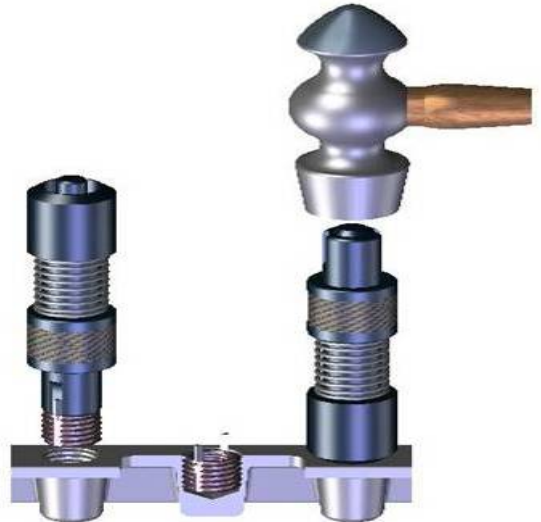



ARCONIC

# KEENSERTS® Inserts Installation, Removal & Broach (Cont'd)

## Insert Removal

It is unlikely that KEENSERTS® inserts will ever have to be removed since their threads are stronger than original threads. If removal is necessary, however, follow these simple steps.

1. Use **standard drill**, as listed for each part number to remove insert material between KEES.
2. Deflect KEES inward and break off.
3. Remove insert with E-Z OUT type tool.
4. An identical insert can now be installed in the original hole. No re-work of the hole will be necessary.

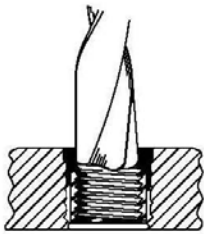

Step 1

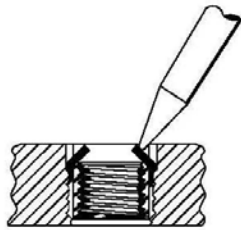

Step 2

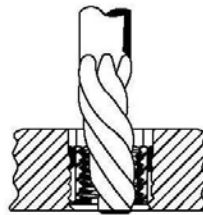

Step 3



Step 4

## Broaching Tool

Broaching Tools are coded in the following manner:

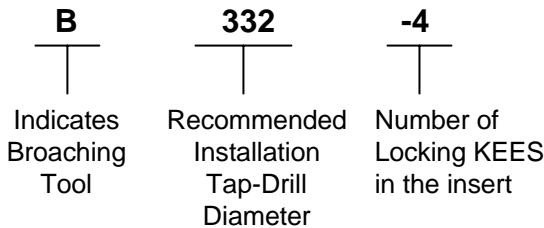

Note: The smallest tap drill diameter for which broaching tools can be made is .213. Consult AFS Customer Applications Engineers for metric broaching tool information.