

SPEC 04612 2-6

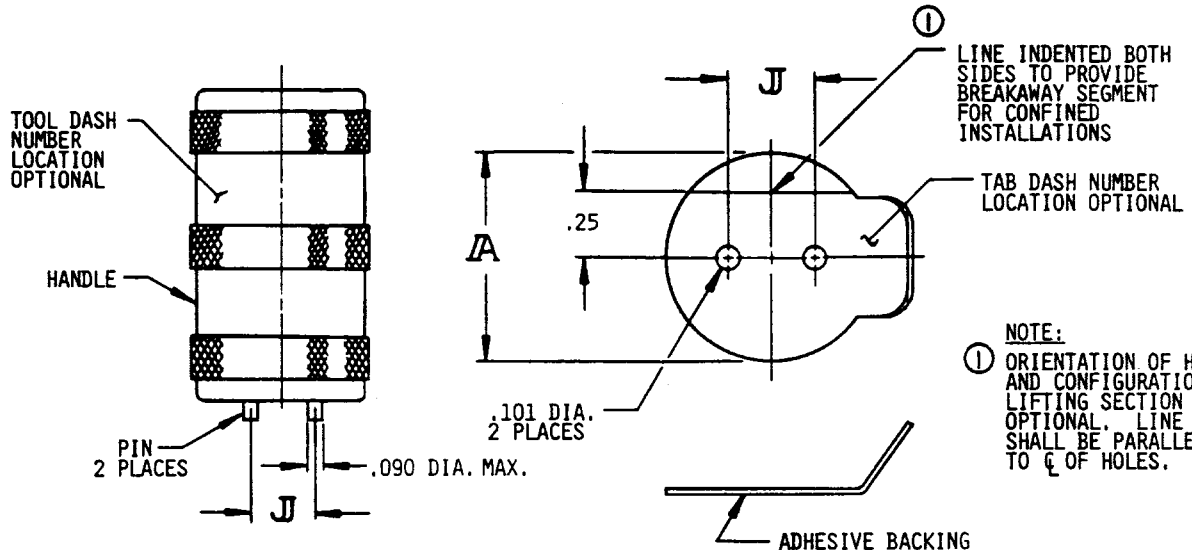

ALIGNING TOOL

INSTALLATION TAB

TABLE I

FOR D1832, D1833 AND D1834

INSERT FIRST DASH NUMBER	ALIGNING TOOL	INSTALLATION TAB	J REF.	A REF.
-06	G3	T3	.367	.90
-08	G3	T3	.367	.90
-3	G3	T3	.367	.90
-4	G6	T6	.467	.90
-5	G6	T6	.467	.90
-6	G9	T9	.591	1.13

TABLE II

FOR D1835

INSERT FIRST DASH NUMBER	ALIGNING TOOL	INSTALLATION TAB	J REF.	A REF.
-08	G7	T7	.500	.90
-3	G7	T7	.500	.90
-4	G9	T9	.591	1.13
-5	G10	T10	.655	1.13
-6	G11	T11	.718	1.13

TABLE III

FOR D1836

INSERT FIRST DASH NUMBER	ALIGNING TOOL	INSTALLATION TAB	J REF.	A REF.
-06	G2	T2	.358	.90
-08	G2	T2	.358	.90
-3	G2	T2	.358	.90
-4	G4	T4	.405	.90

NOTES:

- MATERIAL AND FINISH: ALIGNING TOOL: HANDLE - AL ALLOY, ANODIZED PER MIL-A-8625.  
PINS - CRES, PASSIVATED PER QQ-P-35.  
INSTALLATION TAB: ADHESIVE - BACKED AL ALLOY.
- EXAMPLE OF PART NUMBERS:  
D1837G3 ALIGNING TOOL FOR D1832, D1833 AND D1834 INSERT IN SIZES -06, -08 AND -3.  
D1837T7 INSTALLATION TAB FOR D1835 INSERTS IN SIZES -08 AND -3.
- (1) INSTALLATION TABS ARE FURNISHED WITH INSERTS AS SPECIFIED ON THE APPLICABLE STANDARD. USE THIS STANDARD TO ORDER ADDITIONAL TABS ONLY.

DRAWING PROVIDES FORM, FIT AND FUNCTION DATA. DO NOT ATTEMPT TO MANUFACTURE PRODUCT USING THIS DRAWING.

		TITLE: INSTALLATION TAB & ALIGNMENT TOOL FOR D1832, D1833, D1834, D1835 & D1836 MOLDED-IN INSERTS		Rosan / Aerospace Fastener Division Fairchild Fastener Group P.O. BOX 25225 Santa Ana, CA 92799 USA	
DRAWN BY: <i>[Signature]</i> DATE: 5-19-80	DATE: 5-2-80	UNLESS OTHERWISE SPECIFIED: TOLERANCES: MILLIMETERS DECIMALS: .XX ± .02 .XXX ± .010 ANGLES: ± 2°		SURFACE FINISH 125 MICROINCHES	
APPROVED BY: <i>[Signature]</i> DATE: 6-28-80	PROJECT NUMBER: 2	CAGE CODE 83324		SHEET   OF	

REVISION B EGO 6-28-80  
 C 6-24-80  
 D 9/2/80  
 SEE EN 93-06-29