

Voi-Shan • Tridair • Screwcorp

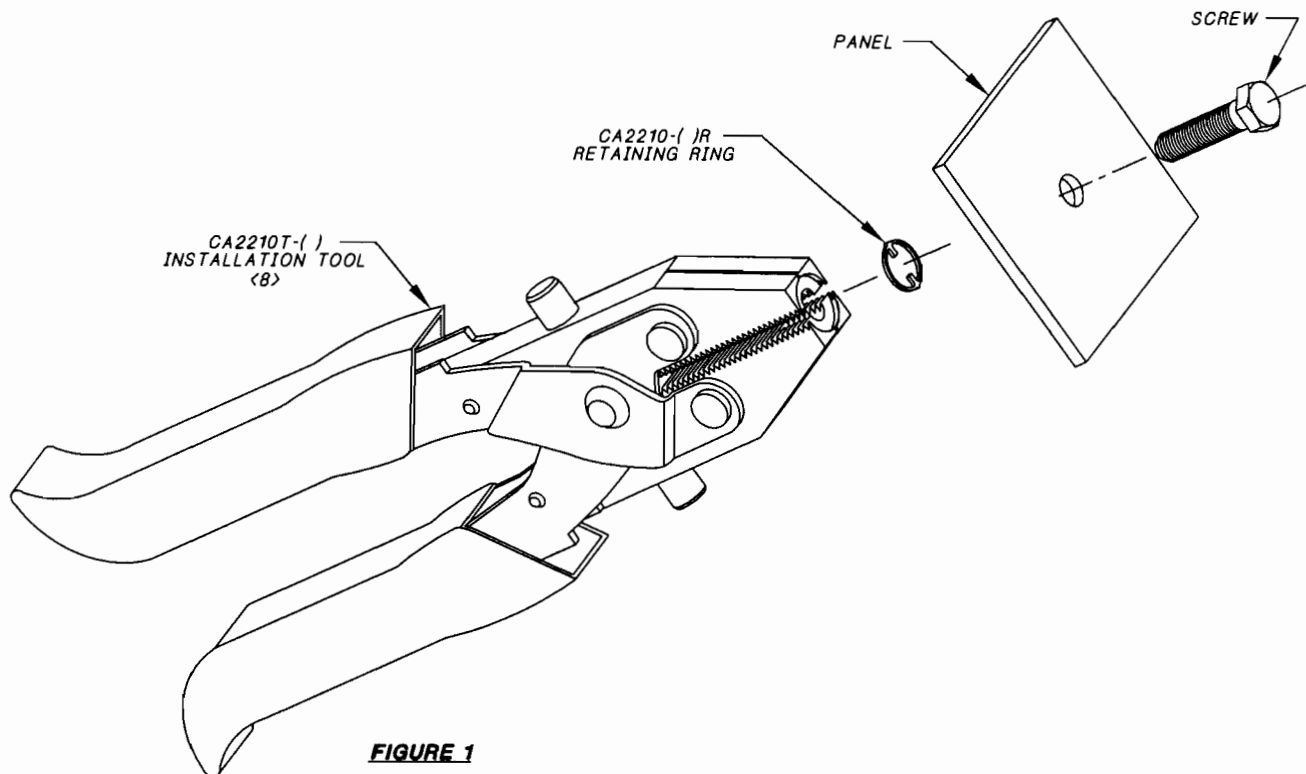

FIGURE 1

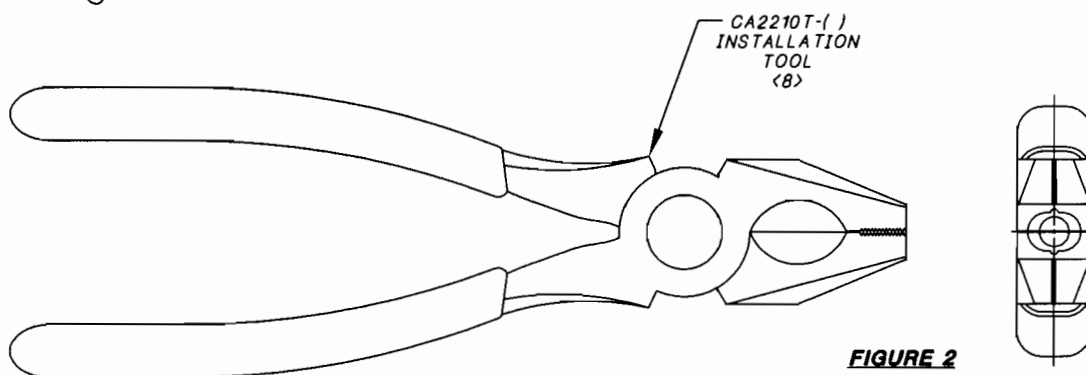

FIGURE 2

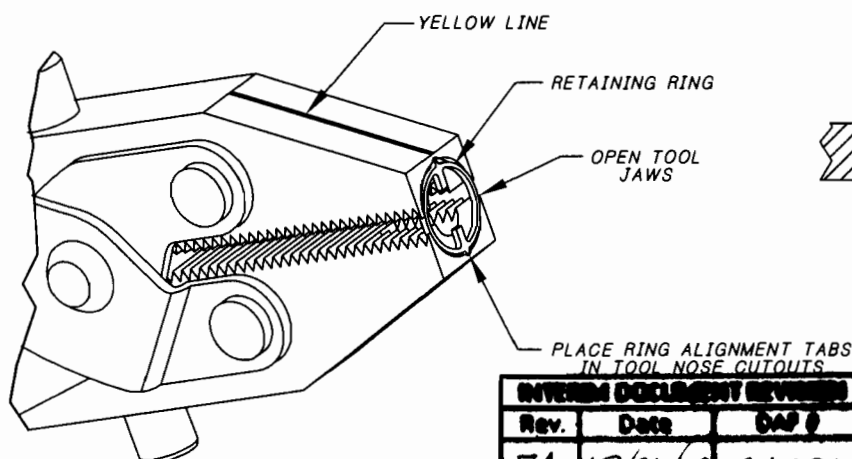

FIGURE 3

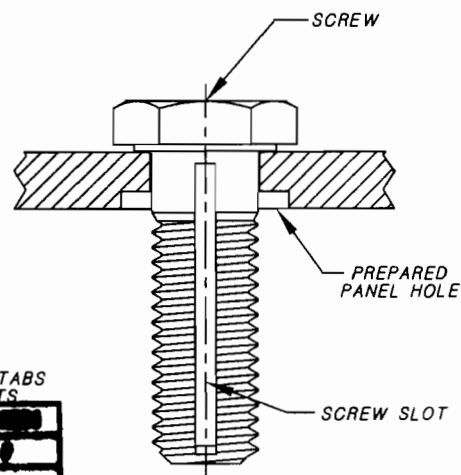

FIGURE 4

APPROVED DATE

19 FEB 90

REV. LETTER AND DATE

~~F~~ 29 JUN 90

DAF NUMBER

~~DAF 42666~~

Fairchild FAIRCHILD FASTENERS
 ENGINEERING CENTER
 3000 WEST LOMITA BOULEVARD
 TORRANCE, CA 90505

CAGE CODE 29372

TRIDAIR PRODUCT

INSTALLATION, CRIMP-ON
 RETAINING RINGS

CA2210T-()

SHEET 1 OF 2

S4287T

SCANNED

Vol-Shan · Tridair · Screwcorp

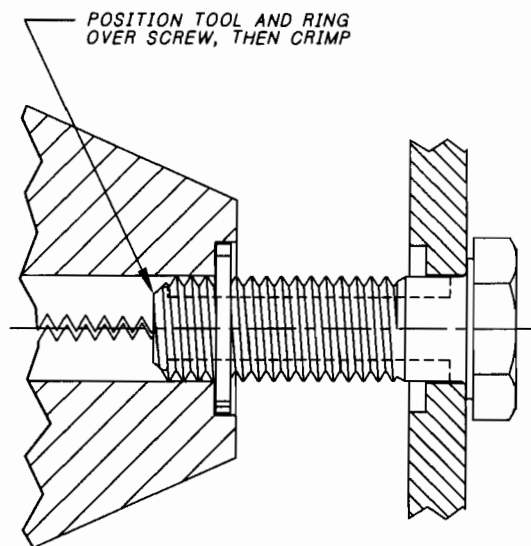

FIGURE 5

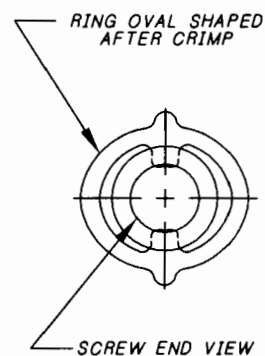

FIGURE 6

INSTALLATION PROCEDURE

1. INSERT THE SCREW IN A PANEL HOLE PREPARED IN ACCORDANCE WITH CAL-STD-0260. SEE FIGURE 4.
2. PLACE THE RETAINING RING IN THE TOOL NOSE AS SHOWN IN FIGURE 3. NOTE THE RING ALIGNMENT TAB PLACEMENT. SQUEEZE THE TOOL ONLY ENOUGH TO HOLD THE RING IN PLACE. "DO NOT CRIMP"
3. ALIGN THE YELLOW LINES ON THE TOOL JAWS WITH THE SCREW SHANK SLOTS AND PLACE THE TOOL OVER THE SCREW THREADS AS SHOWN IN FIGURE 5 (THE RING WILL NOT ALLOW THE SCREW TO ENTER THE TOOL UNLESS THE INTERNAL RING TANGS ARE ALIGNED WITH THE SCREW SLOTS).
4. CRIMP THE RING INTO THE SCREW SLOTS UNTIL THE TOOL JAWS SHUT. IT IS NOT NECESSARY TO SQUEEZE TIGHTLY ONCE THE TOOL JAWS ARE SHUT. SEE FIGURE 6.
5. OPEN THE TOOL JAWS AND REMOVE THE TOOL FROM THE SCREW. CHECK FOR PROPER CRIMP BY PULLING ON THE RING WITH FINGERS. THE RING SHOULD NOT COME OFF THE SCREW. RE-CRIMP, IF NECESSARY.
6. CAUTION:
KEEP THE TOOL JAWS AND NOSE AREA CLEAN AND UNDAMAGED. DEBRIS OR DAMAGE TO TOOL NOSE AREA OR JAWS MAY PREVENT PROPER RING CRIMPING.

(8) INSTALLATION TOOL NUMBER CA2210T-() WAS CHANGED FROM FIGURE 1 TO LOOK LIKE THE PICTURE ON FIGURE 2. TOOLS ORDERED WILL BE SUPPLIED WITH THE PICTURE ON FIGURE 1 UNTIL PRESENT INVENTORIES ARE EXHAUSTED, AFTER WHICH ALL SHIPMENTS WILL HAVE THE TOOL ON FIGURE 2 ONLY.

USE INSTALLATION TOOL NUMBER	RETAINING RING PART NUMBER	SCREW THREAD SIZE REF
CA2210T-06	CA2210-06R	.1380-32UNC-3A
CA2210T-08	CA2210-08R	.1640-32UNC-3A
CA2210T-10	CA2210-10R	.1900-32UNF-3A
CA2210T-4	CA2210-4R	.2500-28UNF-3A
CA2210T-5	CA2210-5R	.3125-24UNF-3A
CA2210T-6	CA2210-6R	.3750-24UNF-3A
CA2210T-7	CA2210-7R	.4375-20UNJF-3A

INTERIM DOCUMENT REVISION		
Rev.	Date	DAF #
F1	10/21/10	94301

APPROVED DATE	19 FEB 90
REV. LETTER AND DATE	F 29 JUN 98
DAF NUMBER	DAF 42005

Fairchild FAIRCHILD FASTENERS
ENGINEERING CENTER
 3000 WEST LOMITA BOULEVARD
 TORRANCE, CA 90505

**INSTALLATION, CRIMP-ON
 RETAINING RINGS**

CAGE CODE **29372**
 TRIDAIR PRODUCT

CA2210T-()

SHEET 2 OF 2

S42817

SCANNED