

Vol-Shan · Tridair · Sorewoorp · Camloc · RAM

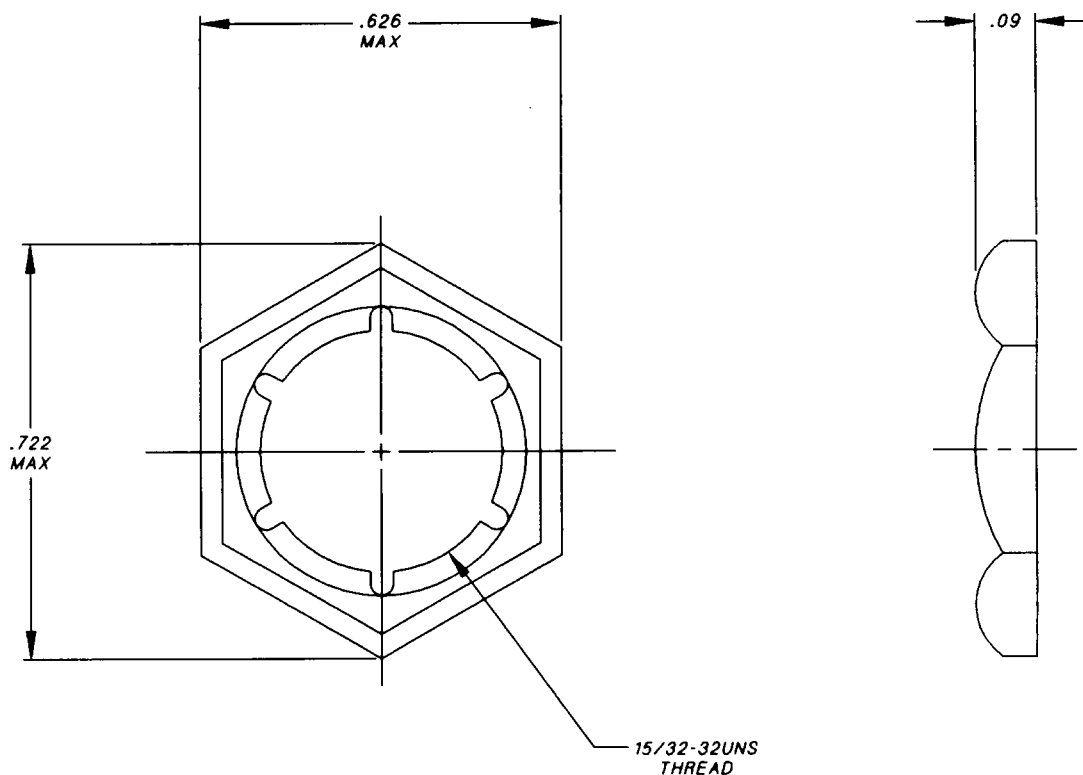

NOTES; UNLESS OTHERWISE SPECIFIED:

- 1. MATERIAL:
  - 1.1 STEEL
- 2. FINISH:
  - 2.1 ZINC PLATED WITH CLEAR CHROMATE.

UNLESS OTHERWISE SPECIFIED DIMENSIONS ARE IN INCHES & PER ANSI Y14.5M-82 TOLERANCES:  
 ANGLES = ±1/2  
 FRACTIONS = ±1/32  
 DECIMALS .XX = ±.02  
 .XXX = ±.010

APPROVED DATE	23 NOV 98
REV. LETTER AND DATE	A 23 NOV 98 PS
DAF NUMBER	DAF 43508

**Fairchild** AEROSPACE FASTENER DIVISION  
 3012 WEST LOMITA BOULEVARD  
 TORRANCE, CA 90505

CAGE CODE	71286
CAMLOC PRODUCT	
<b>99N10</b>	
SHEET	1 OF 1

**NUT  
 LOCK RECEPTACLE RETAINING**

S4445