

REV. A  
DRAWING NO. 701E

STOCK	REV.	CHANGE
OK	A	SEE DAN # 4313
	ORTEGA 11/6/91	WD 10/25/93

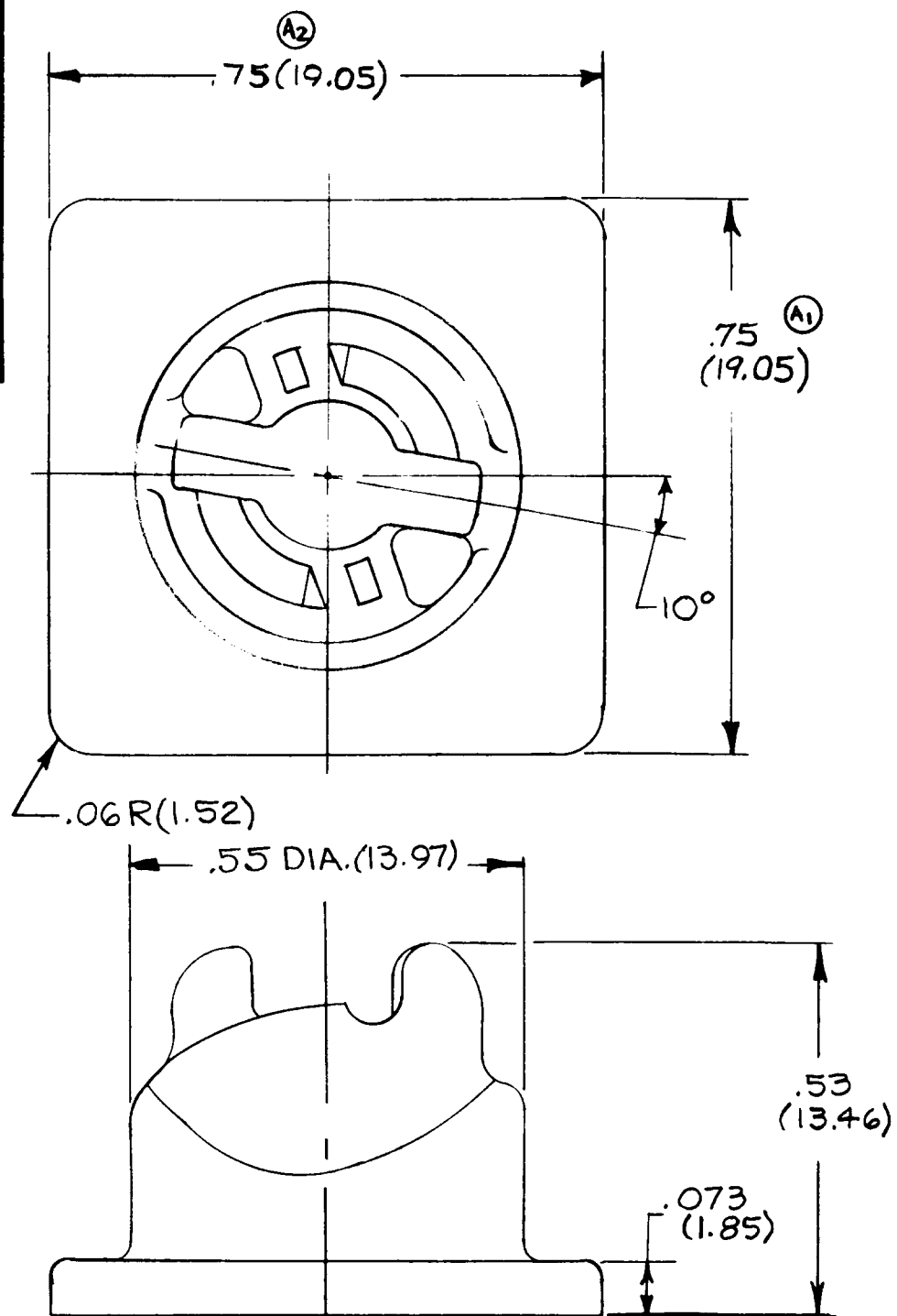

NOTE: 1. FOR INSTALLATION DATA REFER TO CAMLOC CATALOG.

THIS DOCUMENT IS PROTECTED BY COMMON LAW COPYRIGHT. IS RECEIVED IN CONFIDENCE AND SHALL NOT BE REPRODUCED, USED OR DISSEMINATED IN WHOLE OR IN PART WITHOUT WRITTEN PERMISSION OF Rexnord Inc.

**Rexnord Inc.**  
Specialty Fastener Division  
Paramus, New Jersey

MATERIAL	ZINC BASE ALLOY DIE CASTING PER QQ-Z-363	SCALE	4:1 & NOTED	WT.-LBS	1.36/1.00	TITLE	INSERT - ZINC, 1.375, RECEPTACLE, FLOATING TYPE
HEAT TREATMENT	NONE	DR.	J. PAY		4-12-78		
FINISH	ZINC PLATED, QQ-Z-325 CLASS 3, TYPE II, COLORED BLUE	CHK.	<i>W. Seewitz</i>		5-19-78	MODEL OR SERIES	4002
TOLERANCES UNLESS OTHERWISE SPECIFIED:	2 PLACE DEC. ± .02 (± 0.5MM) 3 PLACE DEC. ± .010 (± 0.25MM)	ANG.	± 1°	ENGR. APP.	<i>W. Bross</i>	DRAWING NO.	701E
				SALES APP.	<i>C.T. Handy</i>	REV.	A
					5-19-78	CODE IDENT. NO.	71286

TELETYPE POST 175H 53186 A

1 SCANNED 1