

MANUFACTURE OF THE PROPRIETARY PARTS SHOWN HERE WITHOUT WRITTEN CONSENT IS ABSOLUTELY PROHIBITED

THIS DRAWING EMBODIES A CONFIDENTIAL, PROPRIETARY DESIGN & ALL DESIGN, MANUFACTURING PRODUCTION, USE & SALE RIGHTS REGARDING SAME ARE EXPRESSLY RESERVED.

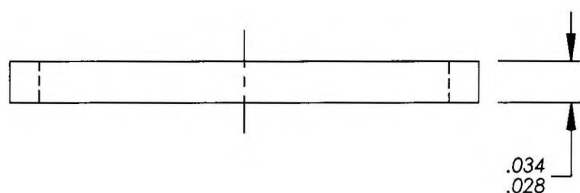
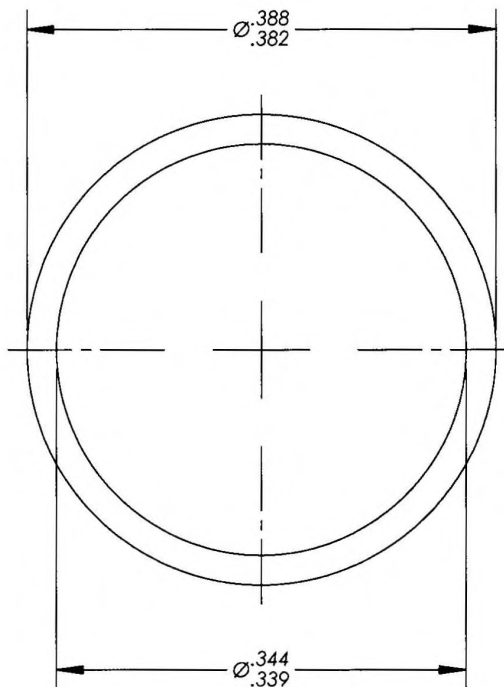
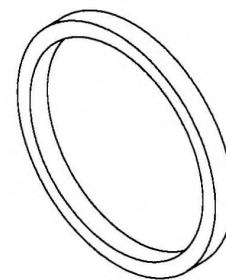

**NOTES:** UNLESS OTHERWISE SPECIFIED

1. MATERIAL:  
1.1 POLYAMIDE (NYLON) PER ASTM D4066 OR L-P-410.
2. FOR INSTALLATION DATA SEE DRAWING 40F7.
3. WEIGHT: .002/100.

INTERIM DOCUMENT REVISION		
Rev.	Date	DAF#
C1	10/8/2018	117431

APPROVED DATE 9 SEP 1953
REV. LETTER AND DATE C 5 JAN 2012
DAF NUMBER 99430

**ARCONIC**  
Arconic Fastening Systems

**CAMLOC PRODUCTS**  
3012 W. LOMITA BLVD.  
TORRANCE, CA 90505-5103

TITLE: **SEAL - NYLON, SPRING CUP TO GROMMET**

UNLESS OTHERWISE SPECIFIED  
DIMENSIONS ARE IN INCHES &  
ASME Y14.5M TOLERANCES:

ANGLES	= ± 1°
FRACTIONS	= ± 1/32
DECIMALS	XX = ± .02
	XXX = ± .010

CURRENT DESIGN ACTIVITY: <b>71286</b>
SALES DRAWING NO. <b>40S39</b>
SHEET 1 OF 1