

MANUFACTURE OF THE PROPRIETARY PARTS SHOWN HERE WITHOUT WRITTEN CONSENT IS ABSOLUTELY PROHIBITED

THIS DRAWING EMBODIES A CONFIDENTIAL, PROPRIETARY DESIGN & ALL DESIGN, MANUFACTURING PRODUCTION, USE & SALE RIGHTS REGARDING SAME ARE EXPRESSLY RESERVED.

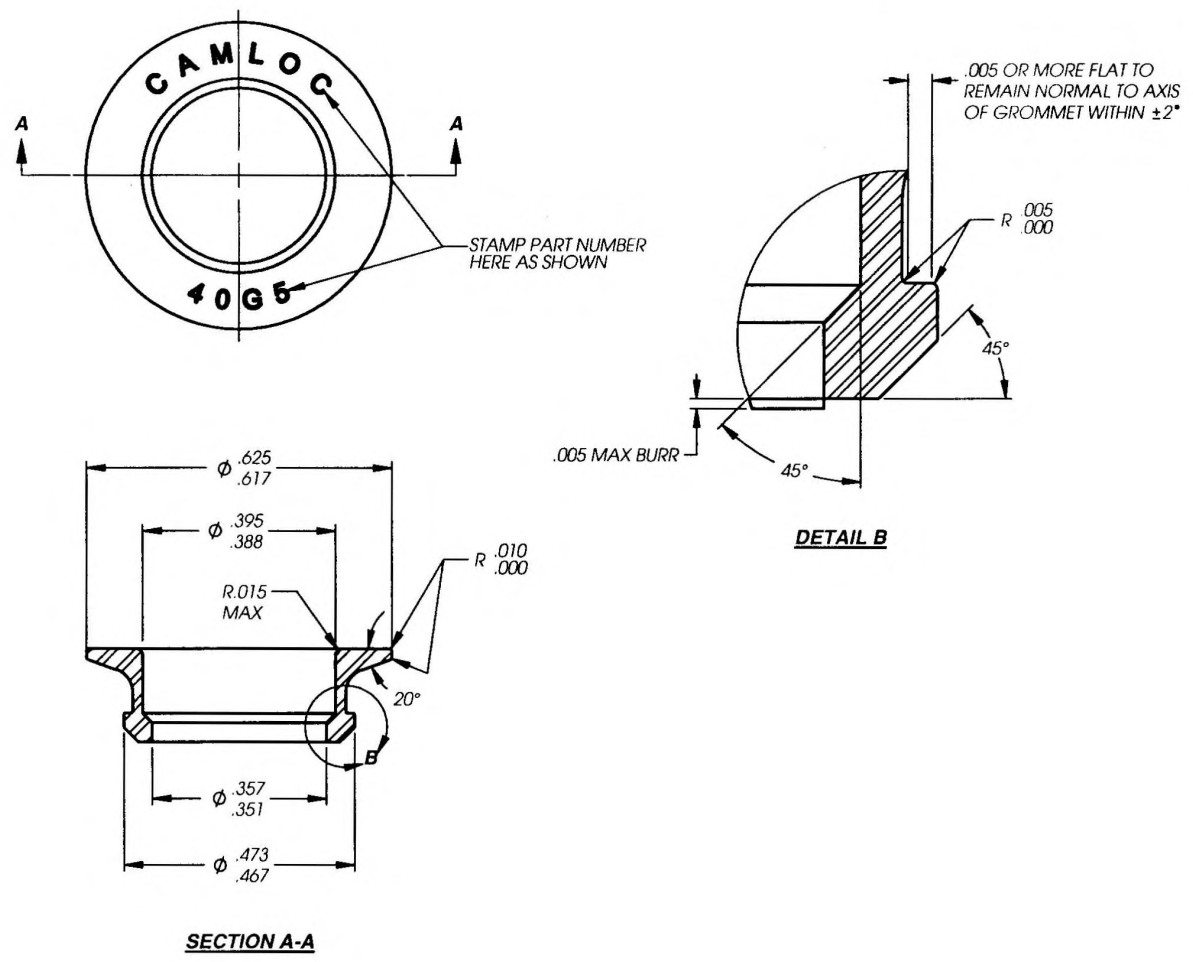

- NOTES:** UNLESS OTHERWISE SPECIFIED.
1. MATERIAL: ALLOY STEEL 4130 PER ASTM A331
 2. HEAT TREAT: 150 KSI MIN TS (REF: 33-42 HRC)
 3. FINISH: CADMIUM PLATE PER AMS-QQ-P-416, TYPE II, CLASS 2 (OLIVE DRAB IRIDITE # 1)
 4. FOR INSTALLATION PROCEDURE, SEE CAMLOC CATALOG USE SAME PREPARATION METHOD AS 4002-G.
 5. ALL EDGES BROKEN .005 MAX AND ALL FINS AND BURRS REMOVED EXCEPT WHERE OTHERWISE SPECIFIED.

INTERIM DOCUMENT REVISION		
Rev.	Date	DAF#
L1	10/8/2018	117431

APPROVED DATE 05-07-02 REV. LETTER AND DATE L 05-07-02 DAF NUMBER 83363	CURRENT DESIGN ACTIVITY: ARCONIC Arconic Fastening Systems CAMLOC PRODUCTS 3012 W. LOMITA BLVD. TORRANCE, CA 90505	TITLE: <p style="text-align: center;">GROMMET-FLUSH, HIGH STRENGTH</p> <p style="font-size: small;">UNLESS OTHERWISE SPECIFIED DIMENSIONS ARE IN INCHES & ASME Y14.5M TOLERANCES:</p> <table style="font-size: x-small; margin-left: auto; margin-right: auto;"> <tr><td>ANGLES</td><td>= ±1°</td></tr> <tr><td>FRACTIONS</td><td>= ±1/32</td></tr> <tr><td>DECIMALS</td><td>.XX = ±.02</td></tr> <tr><td></td><td>.XXX = ±.010</td></tr> </table>	ANGLES	= ±1°	FRACTIONS	= ±1/32	DECIMALS	.XX = ±.02		.XXX = ±.010	CURRENT DESIGN ACTIVITY: CAGE CODE: 71286 SALES DRAWING NO. <p style="font-size: large; text-align: center;">40G5</p> SHEET 1 OF 1
ANGLES	= ±1°										
FRACTIONS	= ±1/32										
DECIMALS	.XX = ±.02										
	.XXX = ±.010										

SCANNED