

MANUFACTURE OF THE PROPRIETARY PARTS SHOWN HERE WITHOUT WRITTEN CONSENT IS ABSOLUTELY PROHIBITED

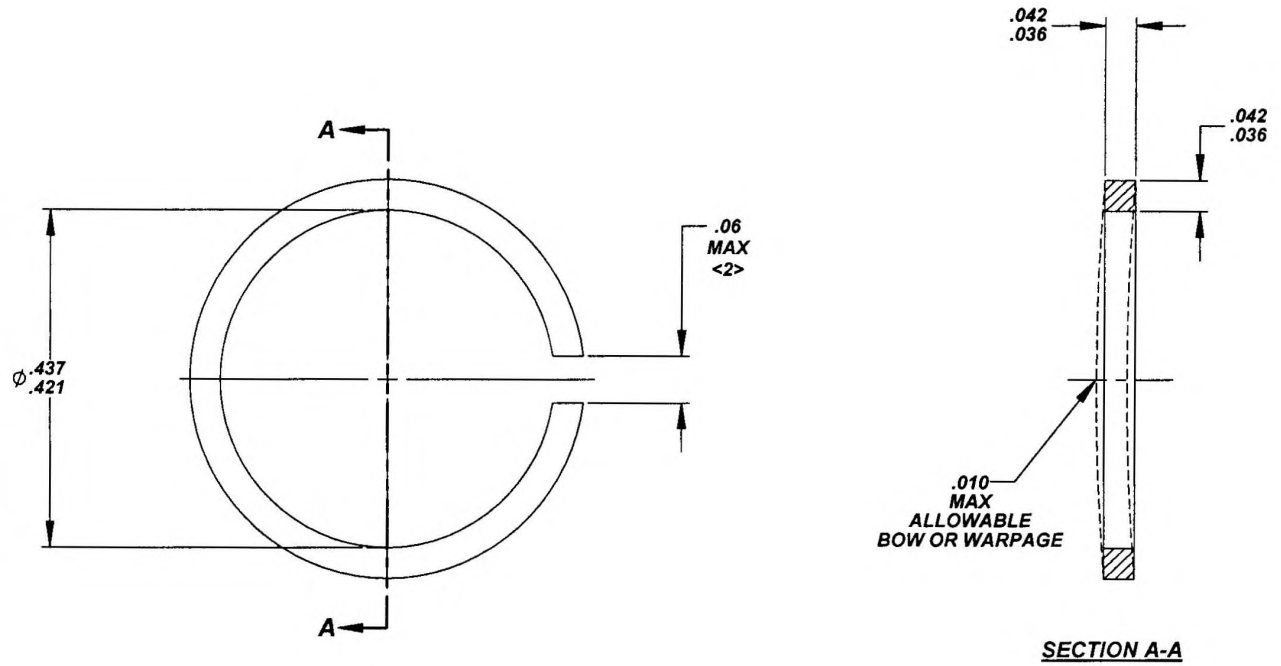

TABLE 1

PART NUMBER	MATERIAL	HEAT TREATMENT	SURFACE FINISH
40G26-1	COBALT ALLOY (ELGILOY)	280 KSI MINIMUM TS	PASSIVATED PER AMS2700

NOTES; UNLESS OTHERWISE SPECIFIED:

- FOR INSTALLATION DATA, SEE CAMLOC DRAWING 40F15.
- <2> SLOT IS AT RANDOM, NOT NECESSARILY RADIALLY FROM CENTER OF RING.

THIS DRAWING EMBODIES A CONFIDENTIAL, PROPRIETARY DESIGN & ALL DESIGN, MANUFACTURING PRODUCTION, USE & SALE RIGHTS REGARDING SAME ARE EXPRESSLY RESERVED.

INTERIM DOCUMENT REVISION		
Rev.	Date	DAF#
G 1	10/8/2018	117431

S45490	APPROVED DATE 6 APR 15	 ARCONIC Arconic Fastening Systems CAMLOC PRODUCTS 3012 W. LOMITA BLVD. TORRANCE, CA 90505-5103	TITLE: RING - SNAP, CRE NON-MAGNETIC, GROMMET	CURRENT DESIGN ACTIVITY: 7 1 2 8 6
	REV. LETTER AND DATE G 30 MAR 16		SALES DRAWING NO.	
	DAF NUMBER DAF 113913		40G26	SHEET 1 OF 1

UNLESS OTHERWISE SPECIFIED DIMENSIONS ARE IN INCHES & ASME Y14.5M TOLERANCES:
 ANGLES = ± 1°
 FRACTIONS = ± 1/32
 DECIMALS .XX = ± .02
 .XXX = ± .010