

MANUFACTURE OF THE PROPRIETARY PARTS SHOWN HERE WITHOUT WRITTEN CONSENT OF HOWMET FASTENING SYSTEMS IS ABSOLUTELY PROHIBITED.

THIS DRAWING EMBODIES A CONFIDENTIAL, PROPRIETARY DESIGN & ALL DESIGN, MANUFACTURING PRODUCTION, USE & SALE RIGHTS REGARDING SAME ARE EXPRESSLY RESERVED.

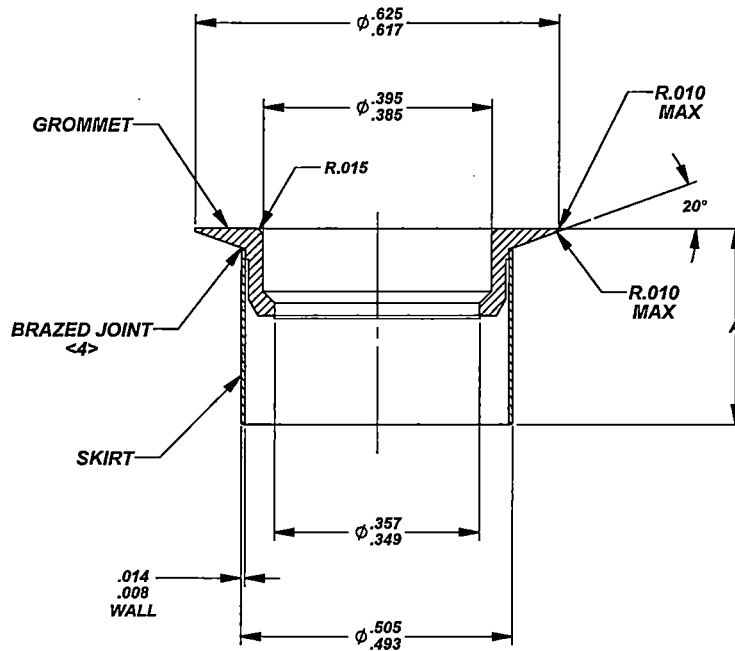
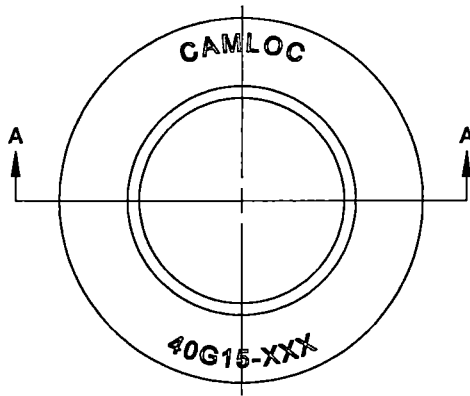

SECTION A-A

NOTES; UNLESS OTHERWISE SPECIFIED:

- 1. FOR INSTALLATION DATA SEE DRAWING NUMBER 40F11.
- 2. ENGINEERING REFERENCE: 40G15-040 AND 40G15-040S FOR DIMPLED INSTALLATION ONLY.
- 3. ALL EDGES BROKEN .005 MAXIMUM AND ALL FINS AND BURRS REMOVED.

<4> BRAZE MUST BE CONTINUOUS AROUND THE OUTSIDE CIRCUMFERENCE OF THE JOINT BRAZE MATERIAL MAY NOT BE VISIBLE ON INSIDE OF GROMMET AND WILL NOT FILL GAP BETWEEN SKIRT AND GROMMET.

S45570	APPROVED DATE 9 SEP 99	Howmet Fastening Systems (HFS) TORRANCE OPERATIONS CAMLOC PRODUCTS 3012 W. LOMITA BLVD. TORRANCE, CA 90505-5103	TITLE: GROMMET - FLUSH FLARED TYPE	CURRENT DESIGN ACTIVITY: 7 1 2 8 6
	REV. LETTER AND DATE L 23 APR 24			SALES DRAWING NO.
	DAF NUMBER DAF 123034			40G15
			UNLESS OTHERWISE SPECIFIED DIMENSIONS ARE IN INCHES & ASME Y:4.5M TOLERANCES: ANGLES = ± 3° FRACTIONS = ± 1/32 DECIMALS .XX = ± .02 .XXX = ± .010	SHEET 1 OF 2

40G15 - () - ()

MANUFACTURE OF THE PROPRIETARY PARTS SHOWN HERE WITHOUT WRITTEN CONSENT OF HOWMET FASTENING SYSTEMS IS ABSOLUTELY PROHIBITED.

THIS DRAWING EMBODIES A CONFIDENTIAL, PROPRIETARY DESIGN & ALL DESIGN, MANUFACTURING PRODUCTION, USE & SALE RIGHTS REGARDING SAME ARE EXPRESSLY RESERVED.

TABLE 1

SUFFIX	MATERIAL		HEAT TREATMENT	FINISH
	GROMMET	SKIRT		
NONE	STEEL ALLOY PER ASTM A304	STEEL ALLOY PER ASTM A108 OR ASTM A519	150 KSI MINIMUM TS PER AMS2759 (EXCEPT SKIRT)	CADMIUM PLATE PER AMS-QQ-P-416, TYPE II CLASS 2
S	300 SERIES CRES PER ASTM A582 OR AMS-QQ-S-763	300 SERIES CRES PER ASTM A276 OR AMS A582 OR AMS-T-8506	NONE	PASSIVATED PER AMS2700, TYPE 2
SB				BLACK OXIDE COAT PER MIL-DTL-13924, CLASS 4

TABLE 2

DASH NUMBER	A	WEIGHT-LBS/100		IDENTIFICATION
		STEEL	CRES	
040	.155	.372	.381	40G15-040
070	.145	.364	.373	40G15-070
100	.165	.374	.383	40G15-100
130	.193	.395	.405	40G15-130
160	.220	.416	.426	40G15-160
190	.250	.435	.446	40G15-190
437	.505	.501	.513	40G15-437
500	.567	.527	.540	40G15-500
625	.720	.533	.546	40G15-625
875	.940	.687	.704	40G15-875

S45570	APPROVED DATE 9 SEP 99	Howmet Fastening Systems (HFS) TORRANCE OPERATIONS CAMLOC PRODUCTS 3012 W. LOMITA BLVD. TORRANCE, CA 90505-5103	TITLE: GROMMET - FLUSH FLARED TYPE	CURRENT DESIGN ACTIVITY: 7 1 2 8 6	
	REV. LETTER AND DATE L 23 APR 24		UNLESS OTHERWISE SPECIFIED DIMENSIONS ARE IN INCHES & ASME Y14.6M TOLERANCES:	ANGLES = ± 3° FRACTIONS = ± 1/32 DECIMALS .XX = ± .02 .XXX = ± .010	SALES DRAWING NO.
	DAF NUMBER DAF 123034		40G15	SHEET 2 OF 2	