

MANUFACTURE OF THE PROPRIETARY PARTS SHOWN HERE WITHOUT WRITTEN CONSENT IS ABSOLUTELY PROHIBITED

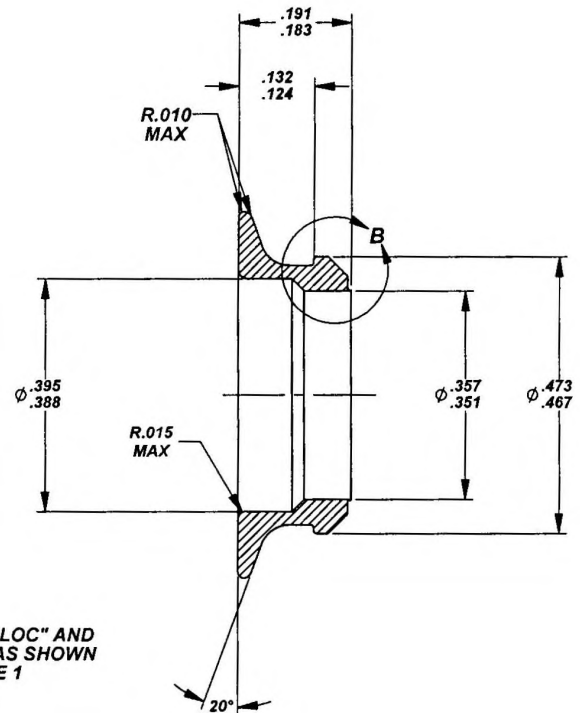

STAMPED "CAMLOC" AND PART NUMBER AS SHOWN IN TABLE 1

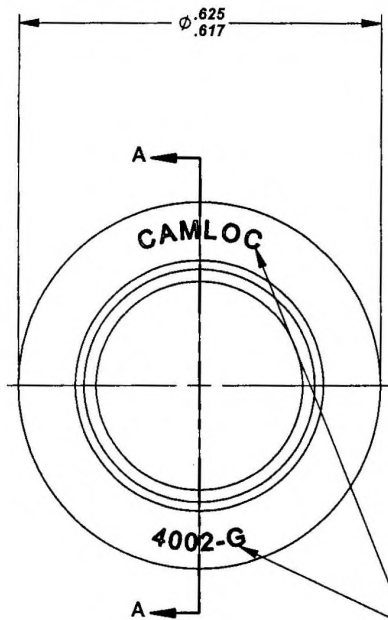
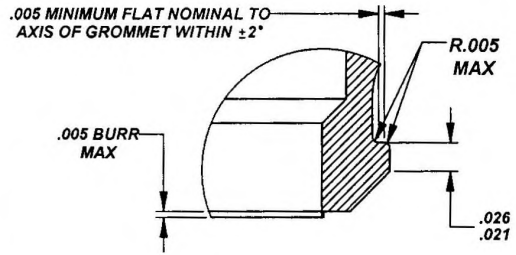

DETAIL - A

TABLE 1

PART NUMBER	MATERIAL	FINISH	WEIGHT LBS/100
4002-G	CARBON STEEL PER ASTM A108	CADMIUM PLATE PER AMS-QQ-P-416, CLASS 2, TYPE II (YELLOW CHROMATE)	.30
4002-G-1		ZINC PLATE PER ASTM B633, CLASS 13, TYPE II (YELLOW CHROMATE)	
4002-G-2		ZINC PLATE PER ASTM B633, CLASS 5, TYPE II (CLEAR CHROMATE)	
4002-G-3		CADMIUM PLATE PER AMS-QQ-P-416, CLASS 2, TYPE I	
4002-G-4		ZINC PLATE PER ASTM B633, CLASS 5, TYPE II (YELLOW CHROMATE)	
<2> 4002-GS	300 SERIES CRES PER ASTM A582	PASSIVATE PER AMS2700, TYPE 2	.31

NOTES; UNLESS OTHERWISE SPECIFIED:

- FOR INSTALLATION PROCEDURE, SEE CAMLOC CATALOG, 4002 SERIES.
- <2> COBENIUM SNAP RING CATALOG NUMBER 40G26 AND 4002 CRES STUD ASSEMBLIES ARE AVAILABLE FOR USE WITH THIS GROMMET.
- ALL EDGES BROKEN .005 MAXIMUM AND ALL FINIS AND BURRS REMOVED EXCEPT WHERE OTHERWISE NOTED.

INTERIM DOCUMENT REVISION		
Rev.	Date	DAF#
W1	10/8/2018	117431

S44106

APPROVED DATE  
23 JUL 48

REV. LETTER AND DATE  
W 17 MAY 16

DAF NUMBER  
DAF 114275

**ARCONIC**  
Arconic Fastening Systems

**CAMLOC PRODUCTS**  
3012 W. LOMITA BLVD.  
TORRANCE, CA 90505-5103

TITLE:  
**GROMMET, FLUSH MOUNTED**

UNLESS OTHERWISE SPECIFIED DIMENSIONS ARE IN INCHES & ASME Y14.5M TOLERANCES:  
 ANGLES = ± 1°  
 FRACTIONS = ± 1/32  
 DECIMALS .XX = ± .02  
 .XXX = ± .010

CURRENT DESIGN ACTIVITY: **7 1 2 8 6**

SALES DRAWING NO.

**4002-G**