

REV. C
DRAWING NO. 2700-ESD

TABLE I	
CATALOG PART NO.	DESCRIPTION
2700-ESD	AS SHOWN

STOCK	REV.	CHANGE
O.K.	B	REDRAWN WITH CHANGES
		BY/DATE CHK/DATE APP
		L.E. BLOODGOOD 5/15/57 J. MARCUS 5-4-57 <i>ATM</i>
OK	C	© WAS "CAMLOC" CAT/PART NO. HERE AS SHOWN. © WAS "CLASS B"
		PAY 11-7-77 WAD <i>WAD</i> 12-1-77

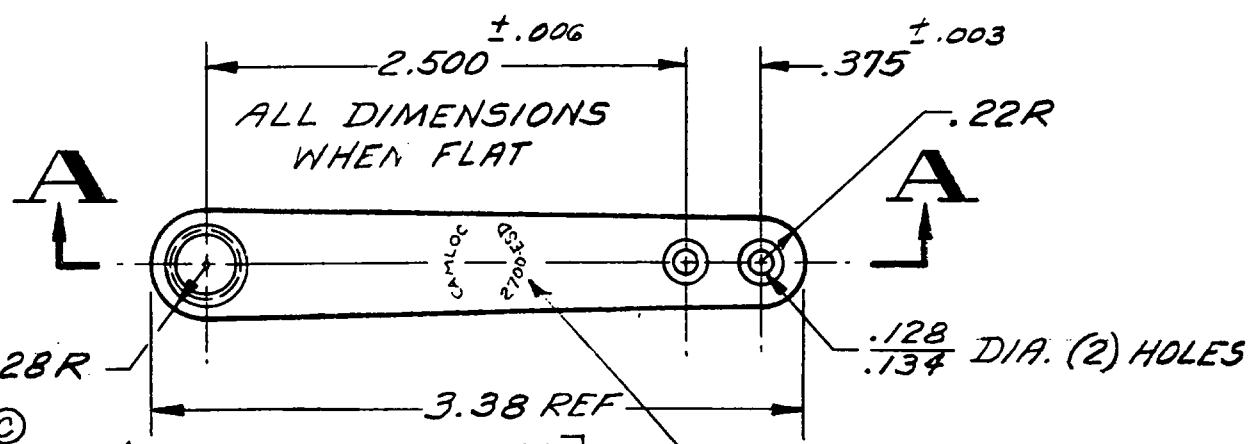

© CAMLOC; CATLOG PART NO. AS SHOWN, RANDOM LOCATION.
MFG. OPTION: SAME IDENT. ON REVERSE SIDE.

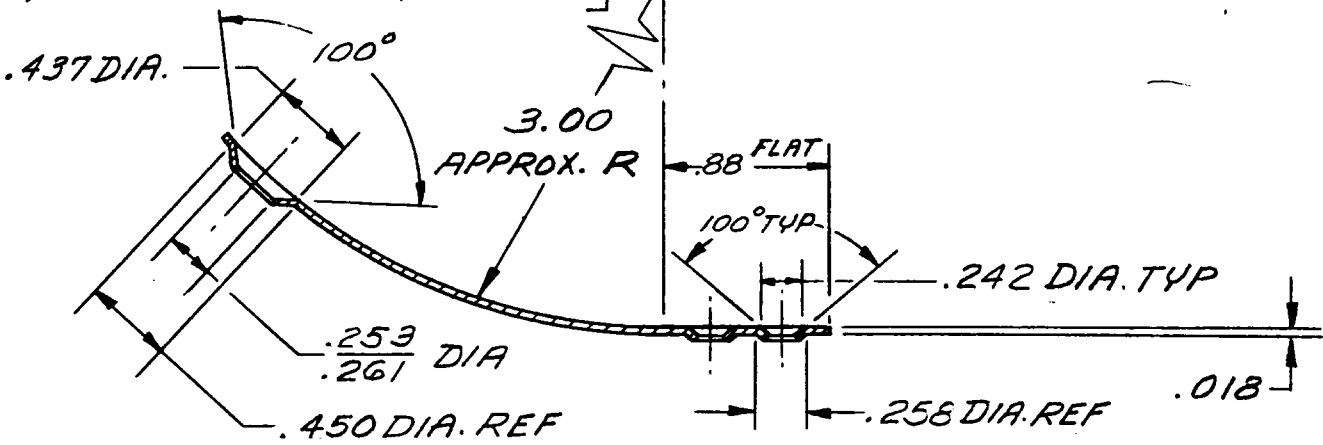

SECTION A-A

1. FOR INSTALLATION DATA REFER TO CAMLOC CATALOG.

Rexnord
We've changed our corporate name to Rexnord Inc.
THIS DRAWING SUPERSEDES 2700-ESD REV. A

THIS DOCUMENT IS PROTECTED BY COMMON LAW COPYRIGHT. IS RECEIVED IN CONFIDENCE AND SHALL NOT BE REPRODUCED, USED OR DISSEMINATED IN WHOLE OR IN PART WITHOUT WRITTEN PERMISSION OF CAMLOC FASTENER CORP.

CAMLOC FASTENER CORPORATION
PARAMUS, NEW JERSEY

FINISH CAD PLATE QQ-P. 416 TYPE II CLASS 2 (C1)	SCALE FULL SIZE	WEIGHT 3.45/100	TITLE SPRING-EJECTOR, STUD, DIMPLED RIVET HOLES
HEAT TREATMENT SPRING TEMPER	DR. ROGOISH	DATE 2-8-52	
MATERIAL SPRING STEEL	CHK. NEWCOMER	DATE 3-11-52	
TOLERANCES UNLESS OTHERWISE SPECIFIED: 2 PLACE DEC. ± .02 ANG. ± 1°	ENGR. APP. R.S.W.	DATE 3-19-52	MODEL OR SERIES 2700
	SALES APP. W.E. B.	DATE 5-17-57	DRAWING NO. 2700-ESD
			REV. C