

Voi-Shan • Tridair • Screwcorp • Camloc • RAM

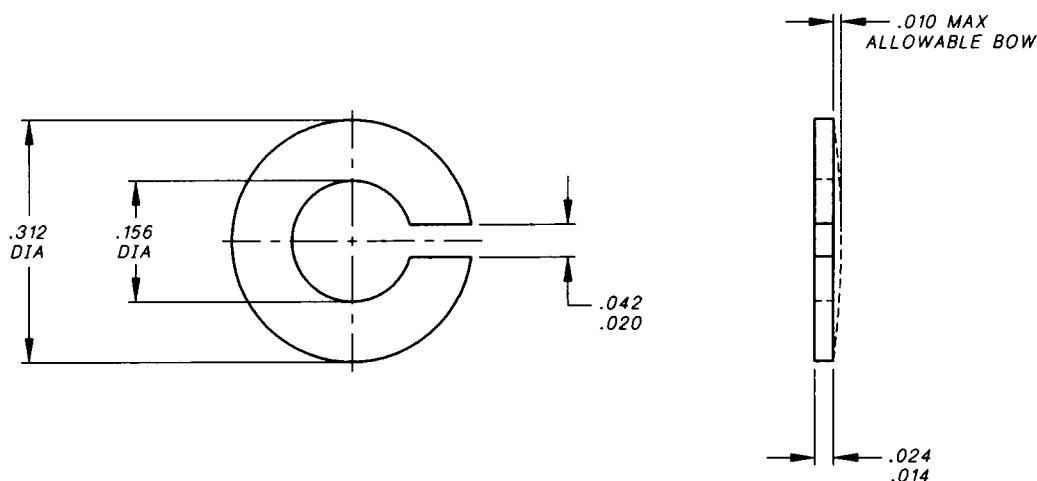

NOTES; UNLESS OTHERWISE SPECIFIED.

1. INSTALLATION PROCEDURE PER CAMLOC CATALOG, SECTION RETAINING RINGS.

**PART NO. CALLOUT:
2600-SW()**

SUFFIX	MATERIAL	HEAT TREAT	FINISH	APPROX. WEIGHT LBS/100
NONE	302 CRES PER ASTM-A-666	NONE	PASSIVATE	.03
2	1095 CARBON STEEL PER ASTM A682 OR ASTM A684	200-260 KSI PER MIL-H-6875	CADMIUM PLATE PER QQ-P-416, TYPE II, CLASS 2	
3			ZINC PLATE PER ASTM B633, CLASS 8, CLEAR CHROMATE	
4			ZINC PLATE PER ASTM B633, CLASS 8, YELLOW CHROMATE	

UNLESS OTHERWISE SPECIFIED DIMENSIONS
ARE IN INCHES & PER ANSI Y14.5M-82
TOLERANCES:

ANGLES = ±1°
FRACTIONS = ±1/32
DECIMALS .XX = ±.02
.XXX = ±.010

APPROVED DATE	 AEROSPACE FASTENER DIVISION 3012 WEST LOMITA BOULEVARD TORRANCE, CA 90505	CAGE CODE 71286	
11 SEP 97		CAMLOC PRODUCT	
REV. LETTER AND DATE		WASHER RETAINING, SPLIT	2600-SW
N 25 AUG 99 <i>PS</i>			
DAF NUMBER	DAF 45302		

S44165