

Voi-Shan • Tridair • Screwcorp

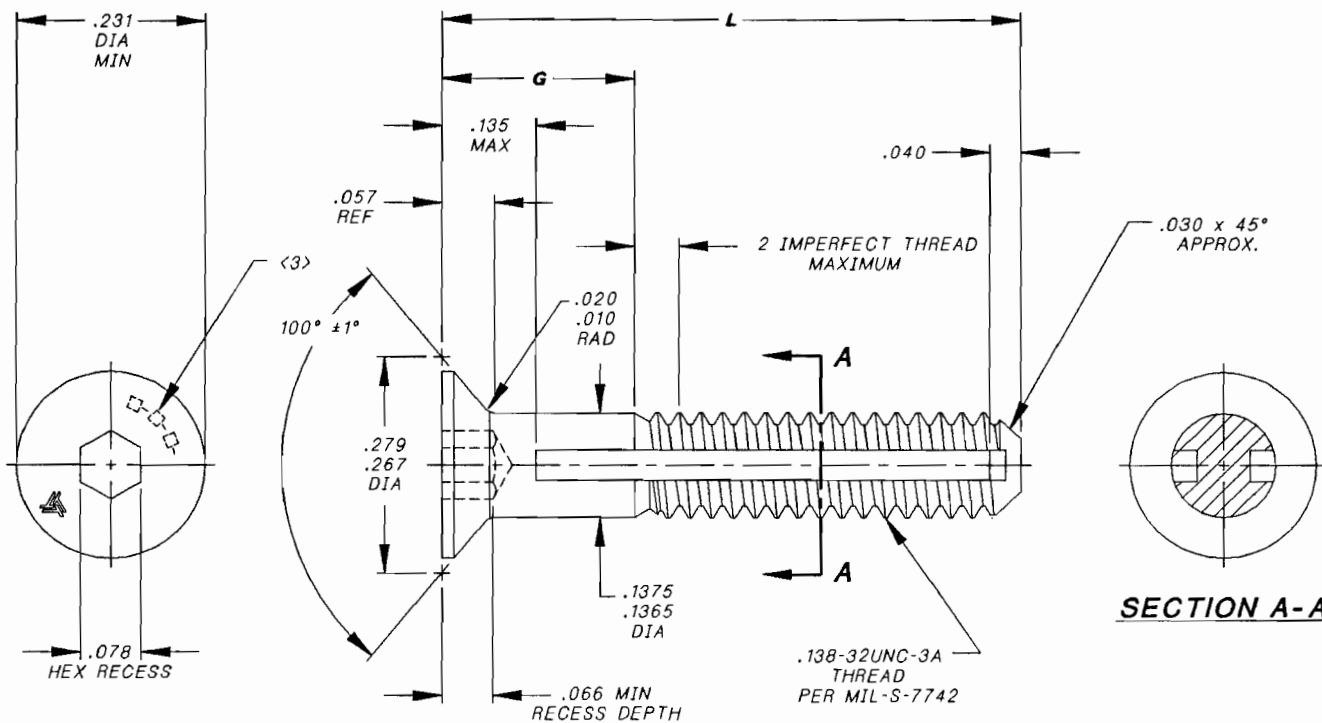

| G GRIP |       |       |       |       |       |        | L LENGTH |
|--------|-------|-------|-------|-------|-------|--------|----------|
| .125   | .156  | .187  | .218  | .250  | .281  | .312   | .437     |
| -4-7   | -5-7  | -6-7  | -7-7  | -8-7  |       |        | .500     |
| -4-8   | -5-8  | -6-8  | -7-8  | -8-8  | -9-8  |        | .562     |
| -4-9   | -5-9  | -6-9  | -7-9  | -8-9  | -9-9  | -10-9  | .625     |
| -4-10  | -5-10 | -6-10 | -7-10 | -8-10 | -9-10 | -10-10 | .687     |
| -4-11  | -5-11 | -6-11 | -7-11 | -8-11 | -9-11 | -10-11 | .750     |
| -4-12  | -5-12 | -6-12 | -7-12 | -8-12 | -9-12 | -10-12 | .812     |
| -4-13  | -5-13 | -6-13 | -7-13 | -8-13 | -9-13 | -10-13 | .875     |
| -4-14  | -5-14 | -6-14 | -7-14 | -8-14 | -9-14 | -10-14 | .937     |
| -4-15  | -5-15 | -6-15 | -7-15 | -8-15 | -9-15 | -10-15 | 1.000    |
| -4-16  | -5-16 | -6-16 | -7-16 | -8-16 | -9-16 | -10-16 | 1.062    |
| -4-17  | -5-17 | -6-17 | -7-17 | -8-17 | -9-17 | -10-17 | 1.125    |
| -4-18  | -5-18 | -6-18 | -7-18 | -8-18 | -9-18 | -10-18 | 1.187    |
| -4-19  | -5-19 | -6-19 | -7-19 | -8-19 | -9-19 | -10-19 | 1.250    |
| -4-20  | -5-20 | -6-20 | -7-20 | -8-20 | -9-20 | -10-20 | 1.312    |
| -4-21  | -5-21 | -6-21 | -7-21 | -8-21 | -9-21 | -10-21 | 1.375    |
| -4-22  | -5-22 | -6-22 | -7-22 | -8-22 | -9-22 | -10-22 | 1.437    |
| -4-23  | -5-23 | -6-23 | -7-23 | -8-23 | -9-23 | -10-23 | 1.500    |
| -4-24  | -5-24 | -6-24 | -7-24 | -8-24 | -9-24 | -10-24 | 1.562    |
| -4-25  | -5-25 | -6-25 | -7-25 | -8-25 | -9-25 | -10-25 | 1.625    |
| -4-26  | -5-26 | -6-26 | -7-26 | -8-26 | -9-26 | -10-26 | 1.697    |
| -4-27  | -5-27 | -6-27 | -7-27 | -8-27 | -9-27 | -10-27 | 1.750    |
| -4-28  | -5-28 | -6-28 | -7-28 | -8-28 | -9-28 | -10-28 |          |

|                           |       |
|---------------------------|-------|
| INTERIM DOCUMENT REVISION |       |
| Rev.                      | DAF # |
| N/A                       | 94301 |
| Date                      |       |
| 10/21/10                  |       |

PROJECT NUMBER: 93-127

|                      |                      |
|----------------------|----------------------|
| APPROVED DATE        | 3 MAR 93             |
| REV. LETTER AND DATE | <del>3 MAR 93</del>  |
| ECN NUMBER           | <del>ECN 32694</del> |

**Fairchild** AEROSPACE FASTENER DIVISION  
 ENGINEERING CENTER  
 3000 WEST LOMITA BOULEVARD  
 TORRANCE, CA 90505

CAGE CODE 92215  
 TRIDAIR PRODUCT

SCREW, CAPTIVE 100° HEAD,  
 HEX RECESS, #6-32 SIZE

CA2289-06-()-()-()

SHEET 1 OF 2

SCANNED

Voi-Shan • Tridair • Screwcorp

NOTES:

1. MATERIAL: 18-8 TYPE 300 CRES SERIES CRES PER QQ-S-763.
2. FINISH:
  - 2.1 STANDARD: PASSIVATED PER QQ-P-35.
- <3> PART MARKING: HEAD OF SCREW STAMPED .010 MAXIMUM DEEP WITH TRIDAIR LOGO 1ST, 2ND AND 3RD DASH NUMBERS.
4. SCREW TO BE USED WITH CA2210-06R OR CA2210A-06R RETAINING RING TO CAPTIVATE TO PANEL.
5. PANEL PREPARATION: REFER TO TRIDAIR DRAWING NUMBER CAL-STD-0260.
6. INSTALLATION: REFER TO TRIDAIR DRAWING NUMBER CA2210T-().
7. MINIMUM STRENGTHS (CALCULATED).
  - 7.1 ULTIMATE TENSILE: 530 LBS.
  - 7.2 ULTIMATE SINGLE SHEAR: 320 LBS.
8. RECOMMENDED SEATING TORQUE: 6 TO 9 IN-LBS.
9. PART CALLOUT EXAMPLE:

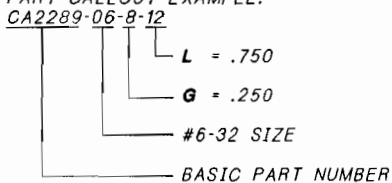

| INTERIM DOCUMENT REVISION |          |       |
|---------------------------|----------|-------|
| Rev.                      | Date     | DAF # |
| N/A1                      | 10/21/10 | 9438  |

PROJECT NUMBER: 93-127

|                      |                       |
|----------------------|-----------------------|
| APPROVED DATE        | 3 MAR 93              |
| REV. LETTER AND DATE | <del>0 MAR 93</del>   |
| ECN NUMBER           | <del>ECN 326947</del> |

**Fairchild** AEROSPACE FASTENER DIVISION  
 ENGINEERING CENTER  
 3000 WEST LOMITA BOULEVARD  
 TORRANCE, CA 90505

CAGE CODE **92215**  
 TRIDAIR PRODUCT

SCREW, CAPTIVE 100° HEAD,  
 HEX RECESS, #6-32 SIZE

CA2289-06-()-()  
 SHEET 2 OF 2

SCANNED