

Voi-Shan • Tridair • Screwcorp

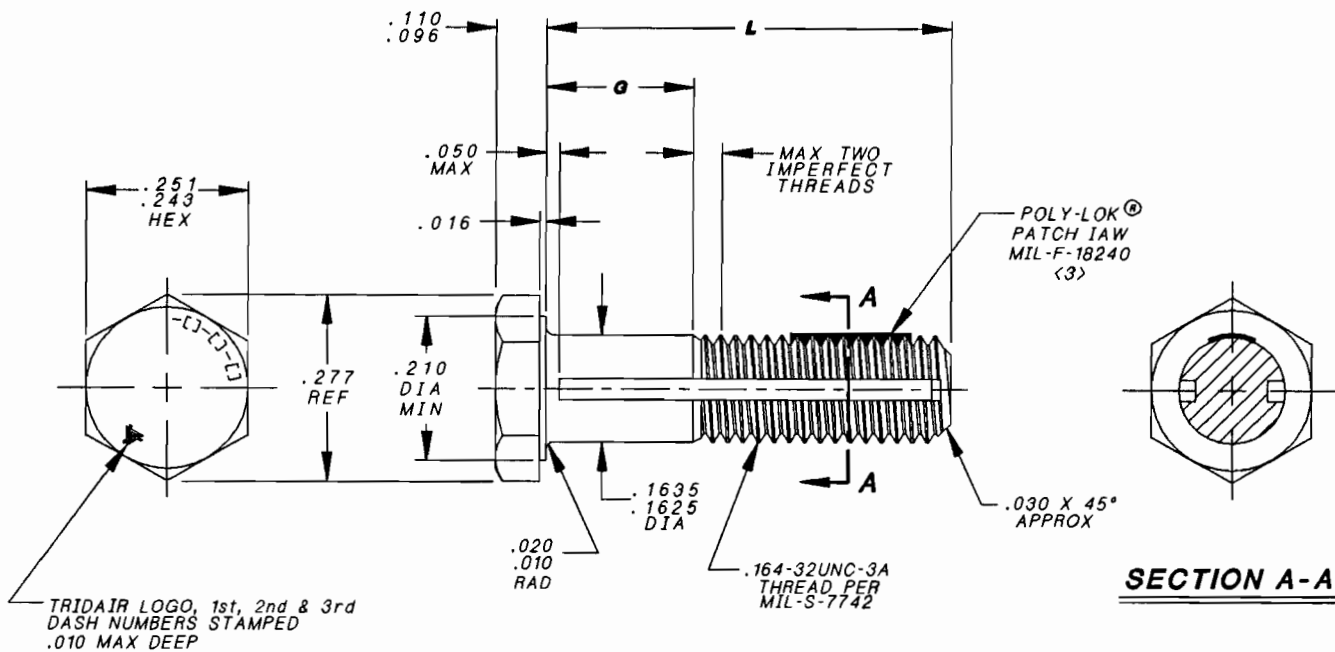

TRIDAIR LOGO, 1st, 2nd & 3rd DASH NUMBERS STAMPED .010 MAX DEEP

.164-32 SIZE FIRST DASH NUMBER -08	g GRIP									L LENGTH
	.062	.094	.125	.156	.187	.218	.250	.281	.312	
-2-8	-3-8	-4-8	-5-8	-6-8	-7-8	-8-8	-9-8	-10-8	.500	
-2-9	-3-9	-4-9	-5-9	-6-9	-7-9	-8-9	-9-9	-10-9	.562	
-2-10	-3-10	-4-10	-5-10	-6-10	-7-10	-8-10	-9-10	-10-10	.625	
-2-11	-3-11	-4-11	-5-11	-6-11	-7-11	-8-11	-9-11	-10-11	.687	
-2-12	-3-12	-4-12	-5-12	-6-12	-7-12	-8-12	-9-12	-10-12	.750	
-2-13	-3-13	-4-13	-5-13	-6-13	-7-13	-8-13	-9-13	-10-13	.812	
-2-14	-3-14	-4-14	-5-14	-6-14	-7-14	-8-14	-9-14	-10-14	.875	
-2-15	-3-15	-4-15	-5-15	-6-15	-7-15	-8-15	-9-15	-10-15	.937	
-2-16	-3-16	-4-16	-5-16	-6-16	-7-16	-8-16	-9-16	-10-16	1.000	
-2-17	-3-17	-4-17	-5-17	-6-17	-7-17	-8-17	-9-17	-10-17	1.062	
-2-18	-3-18	-4-18	-5-18	-6-18	-7-18	-8-18	-9-18	-10-18	1.125	
-2-19	-3-19	-4-19	-5-19	-6-19	-7-19	-8-19	-9-19	-10-19	1.187	
-2-20	-3-20	-4-20	-5-20	-6-20	-7-20	-8-20	-9-20	-10-20	1.250	
-2-21	-3-21	-4-21	-5-21	-6-21	-7-21	-8-21	-9-21	-10-21	1.312	
-2-22	-3-22	-4-22	-5-22	-6-22	-7-22	-8-22	-9-22	-10-22	1.375	
-2-23	-3-23	-4-23	-5-23	-6-23	-7-23	-8-23	-9-23	-10-23	1.437	
-2-24	-3-24	-4-24	-5-24	-6-24	-7-24	-8-24	-9-24	-10-24	1.500	
-2-25	-3-25	-4-25	-5-25	-6-25	-7-25	-8-25	-9-25	-10-25	1.562	
-2-26	-3-26	-4-26	-5-26	-6-26	-7-26	-8-26	-9-26	-10-26	1.625	
-2-27	-3-27	-4-27	-5-27	-6-27	-7-27	-8-27	-9-27	-10-27	1.687	
-2-28	-3-28	-4-28	-5-28	-6-28	-7-28	-8-28	-9-28	-10-28	1.750	

INTERIM DOCUMENT REVISION		
Rev.	Date	DAF #
N/A1	10/21/10	94301

PROJECT NUMBER: 99-052

APPROVED DATE
9 NOV 92
REV. LETTER AND DATE
9 NOV 92
ECN NUMBER
ECN 31815

Fairchild AEROSPACE FASTENER DIVISION
 ENGINEERING R&D CENTER
 1 CIVIC PLAZA, SUITE 500
 CARSON, CA 90745

CAGE CODE 92215
TRIDAIR PRODUCT
CA2275-08L-()-()
SHEET 1 OF 2

SCREW, HEX HEAD,
 CAPTIVE, CRES
 LOCKING PATCH, .164-32 SIZE

SCANNED

Voi-Shan • Tridair • Screwcorp

NOTES:

1. MATERIAL: 18-8 TYPE 300 SERIES CRES PER AMS5640, ASTM-A555, ASTM-A581 OR QQ-S-763.
2. FINISH: PASSIVATE PER QQ-P-35.
- <3> "POLY-LOK" IS A REGISTERED TRADEMARK OF LONG-LOK FASTENERS CORPORATION.
4. RECOMMENDED SEATING TORQUE: 11 TO 17 IN-LBS.
5. MINIMUM ULTIMATE TENSILE STRENGTH (CALCULATED): 820 LBS.
6. MINIMUM ULTIMATE SINGLE SHEAR STRENGTH (CALCULATED): 490 LBS.
7. SCREW TO BE USE WITH CA2210-08R RETAINING RING TO CAPTIVATE TO PANEL.
8. PANEL PREPARATION: REFER TO CAL-STD-0260 FOR .164-32 SCREW THREAD SIZE EXCEPT "A" HOLE DIAMETER TO BE .167 MINIMUM.
9. INSTALLATION: REFER TO TRIDAIR DRAWING CA2210T-1)
11. TOLERANCES, UNLESS OTHERWISE SPECIFIED: .XX ±.02, .XXX± .010, ANGLES: 2°.
12. PART CALLOUT EXAMPLE: CA2275-08L-2-9

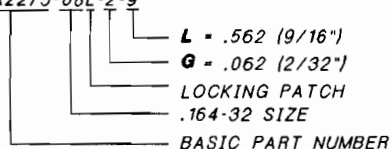

INTERIM DOCUMENT REVISION		
Rev.	Date	DAF #
N/A1	10/21/10	94301

PROJECT NUMBER: 93-052

APPROVED DATE	AEROSPACE FASTENER DIVISION ENGINEERING R&D CENTER 1 CIVIC PLAZA, SUITE 500 CARSON, CA 90745	CAGE CODE 92215
9 NOV 92		TRIDAIR PRODUCT
REV. LETTER AND DATE	SCREW, HEX HEAD, CAPTIVE, CRES LOCKING PATCH, .164-32 SIZE	CA2275-08L-()-()
9 NOV 92		
ECN NUMBER		SHEET 2 OF 2
ECN 31815		

SCANNED